



**INVITATION TO BID
NO. NE II-A1-2023-07**

(CONSTRUCTION OF MCO MULTI-PURPOSE BUILDING)



Table of Contents		
SECTION	SUBJECT	PAGE NO.
	General Overview	0-1
I	Invitation to Bid	I-0
II	Instruction to Bidders	II-0
III	General Conditions of Contract	III-0
IV	Special Conditions of Contract	IV-0
V	General Technical Conditions	V-0
VI	Forms	VI-0
VII	Technical Specifications	VII-0



GENERAL OVERVIEW

This tender document is developed for the Construction of MCO Multi-Purpose Building. It is financed by the 2023 Approved Cash Operating Budget (COB) and made available to Nueva Ecija II Electric Cooperative, Inc.-Area 1 (NEECO II AREA-1). This ITB consists of:

- the invitation to bid;
- the necessary instruction to bidders;
- the general and special conditions of the policy/contract;
- the bid forms and pro-forma contract;
- the Price Schedules under Section VII are to be completed as applicable by the Bidder.

A checklist for the Bidders is attached to this General Overview as Annex A.

CHECKLIST OF ELIGIBILITY REQUIREMENTS

I. ELIGIBILITY REQUIREMENTS (Class "A" Documents)

A. LEGAL DOCUMENTS: FOLDER 1 (ENVELOPE 1)

- 1) DTI Business Name Registration/SEC Registration Certificate, whichever is appropriate under laws of the Philippines
- 2) Valid and Current Mayor's Permit/Municipal License (Principal Place of Business)
- 3) Taxpayer's Identification Number
- 4) BIR Value Added Tax Registration
- 5) Statement that the Bidder is not "Blacklisted" or banned from bidding by the government or any of its agencies, offices, corporation or LGUs, and other private corporations or electric cooperatives; including non-inclusion in the Consolidated Blacklisting Report issued by the Government Procurement Policy Board (GPPB), as provided in Section 69.4 of the IRR-A No. 9184
- 6) Compliance with E.O. # 398
 - a. Proof of VAT Payments for the past 6 months
 - b. Tax Clearance from the BIR to Prove Bidder's Full and Timely Payment of Taxes to the Government
 - c. A Certification under Oath from the Bidders Responsible Officers that the Bidder is Free and Clear of All Liabilities with the Government

B. TECHNICAL DOCUMENTS: FOLDER 2 (ENVELOPE 1)

- 1) Statement in Matrix Form all ongoing and completed government and private contracts (service contracts, maintenance contracts, purchase orders, job orders, etc.) within the relevant period, where applicable, including contracts awarded but not yet started, if any. The Statement shall state whether each contract is:
 - a. Ongoing, Completed or Awarded but not yet started; within the relevant period, where applicable. Each Contract should include the following:
 - i. The name of the Contract;
 - ii. Date of the Contract
 - iii. Amount of the Contract and Value of Outstanding Contracts;



- iv. Date of Delivery
- v. End-user's Acceptance, if completed

b. Similar or not similar in nature and complexity to the contract to be bid. For the procurement of goods, a contract shall be considered "similar" to the contract to be bid if it involves goods or related services of the same nature and complexity as those which are the subject of the public bidding is concerned.

- 2) PCAB License (Philippine Contractor's Accreditation Board) for Infrastructure Projects

C. FINANCIAL DOCUMENTS: FOLDER 3 (ENVELOPE 1)

- 1) Complete set of Audited Financial Statements, stamped "received" by the BIR or its duly accredited and authorized institutions, for the immediate preceding year, showing, among others the prospective bidder's total and current assets and liabilities.

Complete set of Financial Statement includes the following:

- 1. Balance Sheet
- 2. Income Sheet
- 3. Statement of Changes in Equity
- 4. Cash Flow Statement
- 5. Notes to Financial Statement
- 6. Statement of Management Responsibility for Financial Statement

- 2) The prospective Bidder's computation for its Net Financial Contracting Capacity (NFCC) or a commitment from a universal or commercial bank to extend to it a credit line if awarded the contract to be bid, in an amount not lower than that set by the procuring entity, which shall be as follows:

The computation of a prospective bidder's NFCC must be at least equal to the ABC to be bid which calculated as follows:

$NFCC = [(Current\ assets\ minus\ current\ liabilities)(K)]$ minus the value of all outstanding or uncompleted portions of the projects under ongoing contracts, including awarded contracts yet to be started, coinciding with the contract to be bid

Where:

K= 10 for a contract duration of one year or less, 15 for a contract duration of more than one year up to two years, and 20 for a contract duration of more than 2 years

CLASS "B" DOCUMENTS: FOLDER 4 (ENVELOPE 1)

- 1) Valid Joint venture Agreement, in case of joint venture. Each Member of the joint venture shall submit the required eligibility documents; and,
- 2) Letter authorizing the BAC or its duly authorized representative/s to verify any or all of the documents submitted for the eligibility check.



ITB NO. NE II-A1-2023-07

- 3) Notarized statement that each of the documents submitted in satisfaction of the eligibility requirements is an authentic and original copy, or a true and faithful reproduction or copy of the original, complete, and that all statements and information provided therein are true and correct.

D. BIDDER'S CHECKLIST: FOLDER 5 (ENVELOPE 1)

- 1) Eligibility and Source Statement for Bidder and Manufacturer
- 2) Power of Attorney
- 3) Letter of Authorization from the manufacturer to the Bidder/Trader to offer their material or equipment
- 4) Letter of Authorization from the Bidder to the Local Agent
- 5) Manufacturer and catalogue number of each offered item indicated
- 6) All additional data to be furnished by the bidder as per technical specifications
- 7) All deviations from the Specifications listed separately in the Form Deviation
- 8) All substitutions, if any, offered as an alternative Bid, clearly marked as such

II. BID PROPOSALS (ENVELOPE 2)

TECHNICAL PROPOSAL (FOLDER 1)

- 1) Bid Security as to form, amount and validity period
- 2) Authority of the Signatory
- 3) Confirming Statement of Delivery Schedule
- 4) Confirming Statement on Warranty Being Offered
- 5) Details of Technical Specification

FINANCIAL PROPOSAL (FOLDER 2)

- 1) Bid Prices in the prescribed bid form

- All pages and all changes initialled.
- Original and a Copy of all documents.



ANNEX A: BIDDER'S CHECKLIST

- Authorized signature on the Bid (Form 1).
- All pages and all changes initialled.
- Bid Security.
- Bid Summary.
- Bid Schedules completed.
- Bidder's Information.
- Eligibility and Source Statement for Bidder and Manufacturer.
- Bidders Qualification, Sales History and Financial Data.
- Power of Attorney.
- Letter of Authorization from the manufacturer to the Bidder/Trader to offer their material or equipment.
- Letter of Authorization from the Bidder to the Local Agent.
- Delivery Schedule duly signed.
- Technical Data Sheets properly filled in for each offered item and duly signed.
- Manufacturer and catalogue number of each offered item indicated.
- All additional data to be furnished by the bidder as per technical specifications.
- All deviations from the Specifications listed separately in the Form Deviations.
- All substitutions, if any, offered as an alternative Bid, clearly marked as such.
- Original and three copies of all documents.

In the absence of any of the above requirements, the bidder's offer is considered to be non-responsive with major deviation from the bidding documents.



SECTION I. INVITATION TO BID

NEECO II-AREA 1's Invitation to Bid No. NE-II-A1-2023-07

The Nueva Ecija II Electric Cooperative, Inc - Area 1 (NEECO II-Area 1) eligible Bidders for the following bidding activities based on Approved Annual Procurement Plan for the year 2023 and Board Resolution No. 09-04-23, Series of 2023

LOT	DESCRIPTION	ABC (Php) (VAT inclusive)	ACCREDITATION FEE (non-refundable)	BID DOCS FEE (non-refundable)
I	Construction of MCO Multi-Purpose Building	15,000,000.00	5,000.00	10,000.00

Schedule of bidding:

- SUBMISSION OF LETTER OF INTENT AND ACCREDITATION : September 27, 2023 (THRU EMAIL)
- PRE-BID CONFERENCE : October 6, 2023 (3:00PM)
- DEADLINE FOR SUBMISSION OF BIDS/BID OPENING : October 11, 2023 (3:00PM)

Participating bidders must be accredited by this Cooperative. Link for accreditation is available upon request to this email: bac_neeco2area1@yahoo.com.ph.

Only accredited bidders who paid accreditation fee and submitted Letter of Intent (LOI) shall receive the link for pre-bid conference. Participating bidders will pay bid documents prior to bid opening schedule.

Bidding document is available in electronic copy and will be posted in Coop's official website: www.neeco2area1.com to be downloaded by the bidders.

Further, a two percent (2%) of ABC bidder's bond is mandatory, which is to be returned immediately after the bid awarding.

NEECO II – Area I reserves the right to reject any or all bids, to waive any formality or technicality therein, to accept the bid that is deemed most advantageous and to annul the bidding process without incurring any liability to any bidder or party. Finally, NEECO II – Area I assumes no obligation to compensate any bidder or party for any loss or expense incurred in the preparation of the bid or participation in the bidding process.

For further inquiries, you may call (044)-411-1007 local 110 and/or email at bac_neeco2area1@yahoo.com.ph and look for Ms. Set Pauline Feliciano.

Ms. Marife Salvador, CPA, MBA
BAC Chair

Engr. Nelson M. Dela Cruz
General Manager



SECTION II. INSTRUCTION TO BIDDERS

TABLE OF CLAUSES

CLAUSE NUMBER	TOPIC	Page Number
1	Source of Funds	II-1
2	Scope of Bid	II-1
3	Eligible Bidders	II-1
4	Eligible Goods	II-2
5	Bidding Requirements	II-2
6	Corrupt, Fraudulent, Collusive, Coercive, And Obstructive Practices	II-2
7	Subcontracts	II-2
8	Pre-Bid Conference	II-2
9	Qualification of Bidder	II-3
10	One Bid per Bidder	II-3
11	Cost of Bidding	II-4
12	Assurance	II-4
13	Contents of Bidding Documents	II-4
14	Clarification of Bidding Documents	II-4
15	Amendment of Bidding Documents	II-4
16	Language of Bid	II-5
17	Documents Comprising the Bid	II-5
18	Bid Prices	II-6
19	Currencies of Bid and Payment	II-7
20	Documents Establishing Eligibility of the Bidder and the Goods	II-7
21	Documents Establishing Bidder's Qualification to Perform The Contract	II-7
22	Documents Establishing the Good's Conformity to the Bidding Documents	II-8
23	Bid Security	II-8
24	Period of Validity of Bids	II-9
25	Alternative Bids	II-9
26	Format and Signing of Bid	II-9
27	Sealing and Marking of Bids	II-10
28	Deadline for Submission of Bids	II-10
29	Late Bids	II-11
30	Modification and Withdrawal of Bids	II-11
31	Opening of Bids by Procuring Entity	II-11
32	Process to Be Confidential	II-11
33	Clarification of Bids	II-12
34	Preliminary Examination of Bids	II-12
35	Conversion to Single Currency	II-12
36	Evaluation and Comparison of Bids	II-12
37	Contacting the Procuring Entity	II-13
38	Procuring Entity's Right to Accept Any Bid and To Reject Any Or All bids	II-13
39	Post Qualification and Award	II-13
40	Notification of Award	II-14
41	Issuance of Notice of Award and Signing of Contract	II-14
42	Performance Security	II-14



1. SOURCE OF FUNDS

- 1.1 The Nueva Ecija II Electric Cooperative, Inc.-Area 1 (NEECO II-Area 1) funded through its NEA approved Cash Operating Budget, the **CONSTRUCTION OF MCO MULTI- PURPOSE BUILDING** amounting to **Fifteen Million Pesos (Php15,000,000.00) VAT inclusive** made available through Board Resolution No. 09-24-22, Series of 2023.
- 1.2 NEECO II-Area 1 requires that bidders and contractors observe the highest standard of ethics during the procurement and execution of such contracts. In pursuance of this policy;
 - a. will reject a proposal for award if it determines that the bidder recommended for award has engaged in corrupt or fraudulent practices in competing for the contract in question;
 - b. will recognize a contractor as ineligible, for a period determined by the NEECO II Area 1, to be awarded a contract if it at any time determines that the contractor has engaged in corrupt or fraudulent practices in competing for, or in executing, another contract.

2. SCOPE OF BID

- 2.1 The Nueva Ecija II Electric Cooperative, Inc.- Area 1 (hereinafter referred to as "**the Procuring Entity**") wishes to receive Bids for the Construction of MCO Multi-Purpose Building and the supply and delivery of goods, labor and materials, services and equipment for the completion thereof (hereinafter referred to as "**Project**").
- 2.2 All Bids are to be completed and returned to the Procuring Entity in accordance with these Instructions to Bidders.

3. ELIGIBLE BIDDERS

- 3.1 The Invitation to Bid is open to all accredited Contractors/contractors from eligible bidders and from eligible source countries meeting both of the following requirements:
 - a. a bidder (including all members of a joint venture) shall be from an eligible source of country; and
 - b. a bidder (including all members of a joint venture) shall not be one of the followings:
 - (i) a firm or an organization which has been engaged by the Procuring Entity to provide consulting services for the preparation related to procurement for or implementation of this project;
 - (ii) any associates/affiliates (inclusive of parent firms) of a firm or an organization mentioned in sub-paragraph (i) above;
 - (iii) a firm or an organization who lends, or temporarily seconds, its personnel to firms or organizations which are engaged in consulting services for the



preparation related to procurement for or implementation of the project, if the personnel would be involved in any capacity on the same project.

4. ELIGIBLE GOODS

- 4.1 Any contract under which Goods are procured from countries other than the eligible source countries as required for the implementation of the project will be eligible if the combined costs of such Goods are less than fifty (50) percent of the price of the said contract.
- 4.2 At the Procuring Entity's request, bidders may be required to provide evidence documents of the origin of the goods.

5. BIDDING REQUIREMENTS

- 5.1 The Bidder, by the act of submitting its Bid, shall be deemed to have inspected the site, determined the general characteristics of the contracted Works and the conditions for this Project, such as (a) location and the nature of the work; (b) climatic conditions; (c) transportation facilities; (d) nature and condition of the terrain, geological conditions at the site communication facilities, requirements, location and availability of construction aggregates and other materials, labor, water, electric power and access roads; and (e) other factors that may affect the cost, duration and execution or implementation of the contract, project, or work and examine all instructions, forms, terms, and project requirements in the Bidding Documents.

6. CORRUPT, FRAUDULENT, COLLUSIVE, COERCIVE, AND OBSTRUCTIVE PRACTICES

- 6.1 The Procuring Entity, as well as the Bidders and Contractors, shall observe the highest standard of ethics during the procurement and execution of the contract. They or through an agent shall not engage in corrupt, fraudulent, collusive, coercive, and obstructive practices defined under Annex "I" of the 2016 revised IRR of RA No. 9184 as well as the procurement guidelines subjected to RA 10531 or other integrity violations in competing for the Project.

7. Subcontracts

- 7.1 The Procuring Entity has prescribed that Subcontracting is not allowed.

8. Pre-Bid Conference

- 8.1 The Procuring Entity will hold a pre-bid conference for this Project on **October 10, 2023 at 2:00 in the afternoon** in Teofilo R. Villanueva Hall, NEECO II-Area 1, Calipahan, Talavera, Nueva Ecija. Non-attendance of the accredited/prospective bidders in the pre-bid conference have waives his rights to make queries and clarification regarding to the said project. However, he will be provided a copy of the bid bulletin.



- 8.2 Only those who submitted Letter of Intent and Accredited Bidders are allowed to join the scheduled Pre-bid Conference.

9. QUALIFICATION OF BIDDER

9.1 Qualification of the Bidder:

To be qualified for award of Contract, bidders shall:

- a. submit a written power of attorney authorizing the signatory of the bid to commit the bidder; and
- b. submit documentary evidence establishing that bidder has adequate experience, financial capacity, and technical capability to undertake the Contract.
- c. have an experience of having completed a Single Largest Completed Contract (SLCC) that is similar to this Project and at least equivalent to seventy five percent (75%) of the ABC.

A contract is considered to be "similar" to the contract to be bid if it has the same or related work categories.

9.2 Bids submitted by a joint venture of two or more firms as partners shall comply with the following requirements.

- a. the bid, and in case of a successful bid, the form of Agreement, shall be signed so as to be legally binding on all partners;
- b. one of the partners shall be authorized to be in charge; and this authorization shall evidence by submitting a power of attorney signed by legally authorized signatories of all the partners;
- c. the partner in charge shall be authorized to incur liabilities, receive payments and receive instructions For and In Behalf of any or all partners of the joint venture;
- d. all partners of the joint venture shall be jointly and severally liable for the execution of the contract in accordance with the contract terms, and a relevant statement to this effect shall be included in the authorization mentioned under (b) above as well as in the Bid Form and the Form of Agreement (in case of a successful bid); and
- e. a copy of the agreement entered into by the joint venture partners shall be submitted with the bid.

10. ONE BID PER BIDDER

- 10.1 Each bidder shall submit only one bid either by itself, or as partner in a joint venture.



11. COST OF BIDDING

11.1 The bidder shall bear all costs associated with the preparation and delivery of its Bid, and the Procuring Entity will in no case be responsible or liable for those costs.

12. ASSURANCE

12.1 The successful bidder will be required to give satisfactory assurance of its ability and intention to deliver the Goods, pursuant to the Contract, within the time set forth therein.

13. CONTENTS OF BIDDING DOCUMENTS

13.1 The bidding documents are those stated below, and should be read in conjunction with any Addenda issued in accordance with Clause 15.

Section I: Invitation to Bid

Section II: Instructions to Bidders;

Section III: General Conditions of Contract;

Section IV: Special Conditions of Contract;

Section V: General Technical Conditions;

Section VI: Sample Forms; and

a. Bid Form and Price Schedule

b. Bid Security Form

c. Contract Form

d. Performance Security Form

Section VII: Technical Specifications

13.2 The bidder is expected to examine the Bidding Documents, including all instructions, forms, terms and specifications. Failure to furnish all information required by the Bidding documents or submission of a Bid not substantially responsive to the Bidding Documents will result in the rejection of the Bid.

14. CLARIFICATION OF BIDDING DOCUMENTS

14.1 Prospective Bidders requiring any further information or clarification of the Bidding Documents may notify the Procuring Entity in writing, electronic mail, or by fax at the Procuring Entity's mailing address indicated in the Invitation for Bids. The Procuring Entity will respond in writing to any request for information or clarification of the Bidding Documents, which it receives not later than five (5) working days prior to the deadline for submission of Bids prescribed by the Procuring Entity. The Procuring Entity's response will be sent in writing, electronic mail, or by fax to all prospective bidders who have received the bidding documents.

15. AMENDMENT OF BIDDING DOCUMENTS

15.1 At any time prior to the deadline for submission of Bids, the Procuring Entity may, for any reason, whether at its own initiative or in response to a clarification requested by a prospective Bidder, modify the Bidding Documents by issuing an addendum.

15.2 The addendum shall be a part of the Bidding Documents, pursuant to Clause 13.1 and shall be communicated in writing, electronic mail, or by fax to all prospective bidders who have received the Bidding Documents, and will be binding on them.



- 15.3 In order to afford prospective Bidders reasonable time in which to take the addendum into account in preparing their bids, the Procuring Entity may, at its discretion, extend the deadline for the submission of Bids in accordance with Clause 28.

16. LANGUAGE OF BID

- 16.1 If the eligibility requirements or statements, the bids, and all other documents for submission to the BAC are in foreign language other than English, it must be accompanied by a translation in English, which shall be authenticated by the appropriate Philippine foreign service establishment, post, or the equivalent office having jurisdiction over the foreign bidder's affairs in the Philippines. The English translation shall govern, for purposes of interpretation of the bid.

17. DOCUMENTS COMPRISING THE BIDS: TECHNICAL AND FINANCIAL COMPONENTS

- 17.1 The Bid prepared by the bidder shall comprise the following components:

- a. The bidder shall complete an original and a copy of the Bid Form and the appropriate Price Schedules furnished in the Bidding Documents, in accordance with Clauses 18 and 19;
- b. documentary evidence establishing, in accordance with Clause 20, that the bidder is eligible to bid and that the Goods to be supplied by the bidder are eligible Goods;
- c. documentary evidence establishing in accordance with Clause 21, that the bidder is qualified to perform the Contract if its Bids is accepted;
- d. documentary evidence establishing, in accordance with Clause 22, that the Goods to be supplied by the bidder conform to the Bidding Documents;
- e. bid security furnished in accordance with Clause 23; and
- f. power of attorney.

- 17.2 A valid PCAB License is required, and in case of joint ventures, a valid special PCAB License, and registration for the type and cost of the contract for this Project. Contractor license must be atleast Category B.

- 17.3 A List of Contractor's key personnel (e.g., Project Manager, Project Engineers, Materials Engineers, and Foremen) assigned to the contract to be bid, with their complete qualification and experience data shall be provided. These key personnel must meet the required minimum years of experience.

- 17.4 A List of Contractor's major equipment units, which are owned, leased, and/or under purchase agreements, supported by proof of ownership, certification of availability of equipment from the equipment lessor/vendor for the duration of the project, as the case may be, must meet the minimum requirements for the contract.



17.5 Any bid exceeding the Approved Budget Contract (ABC) shall not be accepted.

18. BID PRICES

18.1 The bidder shall complete the appropriate Price Schedules included herein, stating the unit prices, total price per item, the total amount and the expected countries of origin of Goods to be supplied under the Contract.

18.2 (Alternative 1:) All Goods are grouped in Bid Packages. See list of Bid packages in Section VI, Specifications. Bid Packages shall not be divided into sub-packages for the purpose of bidding. Bidders are required to bid for the whole package only, otherwise the bid proposal will be considered non-responsive.

-OR-

(Alternative 2 :) The Goods are grouped in a single bid package and the bid package shall not be divided into sub-packages for the purpose of bidding. Bidders are required to bid for the whole package only, otherwise the bid proposal will be considered non-responsive.

18.3 Prices quoted in the Price Schedules should be entered separately in the following manner.

a. For Goods to be offered from within the Procuring Entity's country:

(i) the price of the Goods, quoted ex-factory, ex-warehouse or of-the shelf, as applicable, including all customs duties and sales and other taxes already paid or payable.

(ii) the price of inland transportation, insurance and other local incidental for the delivery of the Goods to their final destination.

b. For Goods to be offered from outside the Procuring Entity's country:

(i) the price of the Goods, quoted CIF port of entry in the Procuring Entity's country;

(ii) the price of inland transportation, insurance and other local costs incidental to delivery of the Goods from the port of entry to their final destination;

(iii) the CIF price or, when the freight and insurance are itemized separately, the FOB price shall be indicated separately, the FOB price shall be indicated separately from any applicable import duties and taxes.

(iv) if the Goods, or portion of the Goods, are exempt from taxes of duties, this should be indicated below by the bidder.

18.4 All bid prices for the given scope of work in the Project as awarded shall be considered as fixed prices, and therefore not subject to price escalation during contract implementation.



19. CURRENCIES OF BID AND PAYMENT

- 19.1 The unit rates and the prices shall be quoted by the bidder separately in;
- a. US Dollar for those inputs to the Works which the bidder expects to supply from outside the Procuring Entity's country (referred to as "the foreign currency requirements"); and
 - b. Philippine Peso for those inputs to the Works which the bidder expects to supply from within the Philippines.
- 19.2 Payment of the contract price shall be made in the currency or currencies in which the bid price is expressed in the bid of the successful bidder.
- 19.3 The rates of exchange to be used by the bidder for currency conversion during bid preparation shall be the selling rates for similar transactions prevailing on the twenty eight (28) days prior to the date of bid opening, as published by Bangko Sentral ng Pilipinas.
- 19.4 All progress payment shall be subject to ten percent (10%) deduction for retention money.

20. DOCUMENTS ESTABLISHING ELIGIBILITY OF THE BIDDER AND THE GOODS

- 20.1 The bidder shall furnish, as part of its Bid, certification establishing both the bidder's eligibility to bid and that the origin of the Goods is an eligible source country, pursuant to Clause 3 and 4.

21. DOCUMENTS ESTABLISHING BIDDER'S QUALIFICATIONS TO PERFORM THE CONTRACT

- 21.1 The documentary evidence of the bidder's qualifications to perform the Contract, if its Bid is accepted, shall establish to the Procuring Entity's satisfaction prior to award of Contract:
- (a) that, in the case of a bidder offering to supply Goods under the Contract which the bidder did not manufacture or otherwise produce, the bidder has been duly authorized by the Goods' manufacturer or producer to supply the Goods to or in the Procuring Entity's country;
 - (b) that the bidder has the financial, technical and production capability necessary to perform the Contract;
 - (b) that, in the case of a bidder not doing business within the Procuring Entity's country, the bidder is, or will be (if the Contract is awarded to it), represented by an agent in that country equipped and able to carry out the maintenance, repair and spare parts stocking obligations prescribed by the Contract.



22. DOCUMENTS ESTABLISHING THE GOODS' CONFORMITY TO THE BIDDING DOCUMENTS

22.1 The documentary evidence of the Goods' conformity to the Bidding Documents may be in the form of literature drawing and data, and shall furnish:

- a. a detailed description of the Goods' essential technical and performance characteristics;
- b. a list, giving full particulars, including available sources and current prices, of all spare parts, special tools, etc., necessary for the proper and continuing functioning of the Goods for a period of one (1) year; and
- c. a clause-by-clause commentary on the specifications, demonstrating the Goods' responsiveness to those Specifications or a statement of deviations and exceptions of the provisions of the Specifications.

22.2 For purpose of the commentary to be furnished pursuant to sub-clause (c) above, the bidder shall note that standards for workmanship, material, and equipment, and references to brand names or catalogue numbers, designated by the Procuring Entity in the Specifications, are intended to be descriptive only and not restrictive. Equipment or materials meeting the internationally accepted standards which ensure quality to or higher than the standards specified will also be accepted. The bidder may substitute other acceptable standards, brand names and/or catalogue numbers in its Bid, provided that it demonstrates to the Procuring Entity's satisfaction that the substitution are equivalent or superior to those designated in the Specifications. Brand names shall be specified only when specific spare parts are required or standardization is necessary.

22.2 The Bidders shall furnish evidence that the Goods offered are of acceptable quality and standards including but not limited to the number of years in production industry, and the number of units of similar capacity that have been produced and sold in which operations satisfied the end users for years.

23. BID SECURITY

23.1 The bidder shall furnish, as part of its bid, a bid security equivalent to **two percent (2%) of the Total ABC** or an equivalent amount in freely convertible currency.

23.2 The bid security is **preferably in the form of a Manager's Check**.

23.3 **Any bid not accompanied by an acceptable bid security shall be rejected outright by the Procuring Entity and will be declared as non-responsive.**

23.4 The bid securities of unsuccessful bidders will be returned as promptly as possible, after the bid awarding or expiration of the period of bid validity.

23.5 The bid security of the successful bidder will be returned when the bidder has signed the Agreement and furnished the required performance security.

23.6 The bid security may be forfeited;



- a. if the bidder withdraws its bid during the period of bid validity; or
- b. if the bidder does not accept the correction of its bid price,
pursuant to Sub-Clause 33; or
- c. in the case of a successful bidder, if it fails within the specified time limit to:
 - (i) sign the Agreement, or
 - (ii) furnish the required performance security.

24. PERIOD OF VALIDITY OF BIDS

- 24.1 Bids shall remain valid for ninety days (90) days after the date of bid closing prescribed by the Procuring Entity, pursuant to Clause 28.
- 24.2 Notwithstanding Clause 24.1 above, the Procuring Entity may solicit bidder's consent to an extension of the period of bid validity. The request and the responses thereto shall be made in writing or by fax. If the bidders agree to the extension request, the validity of the bid security provided under Clause 23 shall also be suitably extended. A bidder may refuse the request without forfeiting its bid security. A bidder granting the request will not be required or permitted to modify its Bid.

25. ALTERNATIVE BIDS

- 25.1 Bidders shall submit Bids, which comply with the Bidding Documents. Alternative Bids will not be considered. The attention of bidders is drawn to the provisions of Clause 34.4 regarding the rejection of Bids, which are not substantially responsive to the requirement of the Bidding Documents.

26. FORMAT AND SIGNING OF BIDS

- 26.1 The original Bid Form and accompanying documents (as specified in Clause 17), clearly marked "Original Bid", a copy with a softcopy must be received by the Procuring Entity at the date, time, and place specified pursuant to Clause 27 and 28. In the event of any discrepancy between the original and the copies, the original shall govern.
- 26.2 The original and a copy of the bid shall be typed or written in indelible ink and shall be signed by the bidder or a person or persons duly authorized to sign on behalf of the bidder. Written power-of-attorney accompanying the Bid shall indicate such authorization. All pages of the Bid, except for un-amended printed literature, shall be initialled by the person or persons signing the Bid. The name and position held by each person signing must be typed or printed below the signature.
- 26.3 The Bid shall contain no interlineations, erasures or overwriting except as necessary to correct errors made by the bidder, in which case such corrections shall be initialled by the person or persons signing the Bid.



27. SEALING AND MARKING OF BIDS

27.1 The bidder shall seal the original and each copy of the Bid in an inner and an outer envelope duly marking the envelopes as "original" and "copy".

27.2 The inner and outer envelopes shall:

- a. be addressed to the Procuring Entity at the following address

Ms. Marife T. Salvador, CPA, MBA
BAC Chairman
Nueva Ecija II Electric Cooperative, Inc. - Area 1
Calipahan, Talavera, Nueva Ecija;and

- b. bear the words "**INVITATION TO BID No. NE-II-A1-2023-07 MCO MULTI-PURPOSE BUILDING** and the words "**DO NOT OPEN BEFORE 2:00 pm of (November 7, 2023)**".

27.3 In addition to the information required in sub-clauses (a) and (b) above, the inner envelope shall indicate the name and address of the bidder to enable the Bid to be returned unopened in case it is declared "Late" pursuant to Clause 29.

27.4 The Procuring Entity may request additional hard copies and/or electronic copies of the Bid. However, failure of the Bidders to comply with the said request shall not be a ground for disqualification.

28. DEADLINE FOR SUBMISSIONS OF BIDS

28.1 The original Bid, together with the required copies, must be received by the Procuring Entity at the address specified in Clause 27.2 not later than **2:00 pm of November 7, 2023**.

28.2 The Procuring Entity may, at its discretion, extend the deadline for the submission of Bids by amending the Bidding Documents in accordance with Clause 15, in which case all rights and obligations of the Procuring Entity and Bidders previously subject to the deadline will thereafter be subject to the deadline as extended.

29. LATE BIDS

29.1 Any Bid received by the Procuring Entity after the deadline for submission of Bids prescribed by the Procuring Entity, pursuant to Clause 28 will be declared "Late" and rejected and returned unopened to the bidder.

30. MODIFICATION AND WITHDRAWAL OF BIDS

30.1 The bidder may modify or withdraw its Bid after the Bid's submission; provided that written notice of the modification or withdrawal is received by the Procuring Entity prior to the deadline prescribed for submission of Bids.

30.2 The bidder's modification or withdrawal notice shall be prepared, sealed, marked, and dispatched in accordance with provisions of Clause 27, with the outer and inner



envelopes additionally marked "MODIFICATION" or "WITHDRAWAL", as appropriate. A withdrawal notice may also be sent by formal written notice but must be followed by a signed confirmation copy.

- 30.3 No Bid may be modified subsequent to the deadline for submission of Bids.
- 30.4 No Bid may be withdrawn in the interval between the deadline for submission of Bids and the expiration of the period of bid validity specified by the bidder on the Bid Form.

31. OPENING OF BIDS BY PROCURING ENTITY

- 31.1 The Procuring Entity will open the Bids, the technical proposal first, in the presence of bidders' representatives who choose to attend at **NEECO II – AREA 1 Teofilo Hall on November 7, 2023**. The bidders' representatives who are present shall sign a register evidencing their attendance. The technical proposal will then be evaluated as per Clause 34.
- 31.2 Bidders found eligible technically will be informed subsequently and asked to be present during the opening of their financial proposals.
- 31.3 The bidders' names, bid prices, all discounts offered, modifications and bid withdrawals, and the presence or absence of the requisite bid security, and such other details as the Procuring Entity, at its discretion, may consider appropriate will be announced and recorded during the opening of bids. Any bid price or discount offered by the bidder in Philippine Peso, which is not read out and recorded during the bid opening, will not be taken into account in bid evaluation. The bidders' authorized representatives will be required to sign the record and document.
- 31.4 Withdrawal of a bid during the interval between the deadline for submission of bids and the expiration of the period of bid validity specified in the Form of Bid may result in the forfeiture of the bid security.

32. PROCESS TO BE CONFIDENTIAL

- 32.1 Information relating to the examination, clarification, evaluation and comparison of Bids and recommendations for award of a contract shall not be disclosed to bidders or any other persons not officially concerned with such process. Any efforts by a bidder to influence the Procuring Entity's processing of Bids or award decisions may result in the rejection of the bidder's Bid. The request for clarification and the response shall be in writing, electronic mail, or by fax, but no change in the price or substance of the bid shall be sought, offered or permitted except as required to confirm the correction of arithmetic errors discovered by the Procuring Entity in the evaluation of the bids in accordance with sub-clauses 34.5/34.6.

33. CLARIFICATIONS OF BIDS

- 33.1 To assist in the examination, evaluation, and comparison of Bids, the Procuring Entity may, at its discretion, ask the bidder for a clarification of its Bid. All responses to request for clarification shall be in writing, and no change in the price or substance of the Bid shall be sought, offered or permitted.



34. PRELIMINARY EXAMINATION OF BIDS

Technical Evaluation:

- 34.1 The Procuring Entity will examine the bids to determine whether they are complete, whether required sureties have been furnished, whether the documents have been properly signed, and whether the bids are generally in order.
- 34.2 Prior to the detailed evaluation, pursuant to Clause 36, the Procuring Entity will determine the substantial responsiveness of each Bid to the Bidding Documents including acceptable quality of the Goods offered, pursuant to Clause 22. A substantially responsive Bid is one which conforms to all the terms and conditions of the Bidding Documents without material deviation.
- 34.3 A Bid determined as not substantially responsive will be rejected by the Procuring Entity and may not subsequently be made responsive by the bidder by correction of the non-conformity.

Financial Evaluation:

- 34.4 Check the bidder's compliance to the financial documents required by the Procuring Entity
- 34.5 Arithmetical errors will be rectified on the following basis. If there is a discrepancy between the unit price and total price per item that is obtained by multiplying the unit price and quantity, the unit price shall prevail and the total price per item will be corrected. If there is a discrepancy between the Total Amount and the sum of the total price per item, the sum of the total price per item shall prevail and the Total Amount will be corrected.
- 34.6 The amount stated in the Form of Bid will be adjusted by the Procuring Entity in accordance with the above procedure for the correction of errors and, shall be considered as binding upon the bidder. If the bidder does not accept the corrected amount of bid, its bid will be rejected, and the bid security may be forfeited in accordance with Sub-Clause 23.6

35. CONVERSION TO SINGLE CURRENCY

- 35.1 The procuring entity will convert the amounts in various currencies in which the Bid Price is payable to Philippine Peso at the selling exchange rates officially prescribed for similar transactions as established by Bangko Sentral ng Pilipinas on the date of bid opening.

36. EVALUATION AND COMPARISON OF BIDS

- 36.1 The Procuring Entity will evaluate and compare the bids previously determined to be substantially responsive, pursuant to Clause 34.
- 36.2 The Procuring Entity's evaluation of a Bid will exclude and not take into account:
- (a) in the case of goods partially or wholly manufactured within the Procuring Entity's country or Goods of foreign origin already located in the Procuring Entity's country, sales and other similar taxes which may be levied on the finished Goods if the Contract is awarded to the bidder;



- (b) in the case of goods to be offered from outside the Procuring Entity's country, customs duties and other similar import duties and taxes which be levied on the Goods if the Contract is awarded to the bidder; and
- (c) any allowance for price adjustment during the period of execution of the contract, if provided in the bid.

36.3 The comparison shall be of:

- (a) the ex-factory/ex-warehouse/off-the-shell price of the Goods to be offered from within the Procuring Entity's country (such price to include all costs as well as duties and taxes paid or payable on components and raw material incorporated or to be incorporated in the Goods): and
- (b) the CIF port-of-entry price of the Goods to be offered from outside the Procuring Entity's country.

36.4 The evaluation of bids shall take into account the price and other commercial features of the offer. In addition, it may also take into account other criteria, such as those in the sample listed below.

- * Contractual and Commercial Deviations
- * Delivery Schedule
- * Operating Costs
- * Functional Guarantee of the Goods
- * Local Handling and Transportation

37. CONTACTING THE PROCURING ENTITY

37.1 Subject to Clause 33, no bidder shall contact the Procuring Entity on any matter relating to its Bid, from the time of bid opening to the time the contract is awarded unless initiated by the Procuring Entity.

37.2 Any effort by a bidder to influence the Procuring Entity in its decision in respect of bid evaluation, bid comparison or Contract award will result in the rejection of the Bidder's Bid.

38. PROCURING ENTITY'S RIGHT TO ACCEPT ANY BID AND TO REJECT ANY OR ALL BIDS

38.1 **The Procuring Entity reserves the right to accept or reject any Bid and to annul the bidding process and reject all Bids at any time prior to award of Contract, without thereby incurring any liability to the affected bidder or bidders or any obligation to inform the affected bidders of the grounds for the Procuring Entity's action.**

39. POST QUALIFICATION AND AWARD

39.1 The Procuring Entity will determine to its satisfaction whether the Bidder selected as having submitted the lowest calculated responsive bidder, responsive bid is qualified to satisfactorily perform the Contract.



- 39.2 The determination will take into account the bidder's financial, technical and production capabilities. It will be based upon an examination of the documentary evidence of the bidder's qualification submitted by the bidder, pursuant to Clause 21, as well as such other information as the Procuring Entity deems necessary and appropriate.
- 39.3 An affirmative determination will be pre-requisite for award of the Contract to the Bidder. A negative determination will result in rejection of the Bidder's bid.
- 39.4 The Procuring entity will award the Contract to the successful bidder whose Bid has been determined the lowest calculated responsive Bid, provided further that the bidder is determined to be qualified to satisfactorily perform the Contract.

40. NOTIFICATION OF AWARD

- 40.1 The Procuring Entity will notify the successful bidder in writing by registered letter, or by fax or email to be confirmed in writing by registered letter or by fax or email, that its Bid has been accepted and on which basis the Bid has been accepted.
- 40.2 The notification of award will constitute the formation of a contract, until the Contract has taken effect pursuant to Clause 41.

41. ISSUANCE NOTICE OF AWARD AND SIGNING OF CONTRACT

- 41.1 At the time of notification of award, the Procuring Entity will send the successful bidder the Notice of Award.
- 41.2 Within five (5) working days of receipt of such Notice of Award the successful bidder shall affix its signature and date in the Notice of Award and return it to the Procuring Entity together with the corresponding Performance Security.
- 41.3 After signing of Notice of Award and posting of Performance Security of the successful bidder, the Procuring Entity will send the Contract Form provided in the Bidding Documents, incorporating all agreements between the parties.
- 41.4 Within five (5) working days of receipt of such Contract Form the successful bidder shall affix its signature and date in the Contract Form and return it to the Procuring Entity
- 41.5 Upon receipt of the signed Contract form, the Procuring Entity will issue Notice to Proceed to the successful bidder.

42. PERFORMANCE SECURITY

- 42.1 **Within ten (10) working days of the receipt of notification of award from the Procuring Entity, the successful bidder shall post the performance security (amounting to 10% of the total awarded project), in Manager's Check form or cash, to be deposited to the Procuring Entity's bank account.**
- 42.2 Failure of successful bidder to comply with the requirements of Clause 41 or 42 shall constitute sufficient grounds for the annulment of the award and forfeiture of the bid security.



ANNEX A: BID EVALUATION PROCEDURE

Step 1 - Submittal of Bid

If a submittal is late, it should not be opened, but should be returned to the Bidder unopened.

Step 2 – Technical Bid Evaluation

During the Bid opening, preliminary examination shall begin by determining that the general conditions of the Bidding Documents have been met in the bid. The following items should be checked to determine whether the Bid is responsive.

- Bid does not show evidence of tampering.
 - Bid is from a Procuring Entity of the Bidding Documents.
 - Bid Addendum received.
 - Bid appears to be complete.
 - Bid on all items per schedule.
 - Bid contains Deviation Form duly filled in
 - Bidder meets the required experience and number of sales
 - Bidder is a registered company
- a. The Bidder and the manufacturer are both from eligible source countries as defined in list of eligible source countries.
- b. The Bid contains a manufacturer's name and catalogue number for each item in the completed bid schedule.
- c. The Bid contains authorization from the manufacturer to supply the goods to the Bidder for this procurement.
- d. The Bid contains a listing, for each item bid, showing the manufacturer's years of manufacture and the international sales for the required number of years. This is to include dollar volume, Procuring Entity, and names and telephone numbers for Procuring Entity contact person(s).
- e. The Bid contains the Technical Data Sheets with the Bidder's guaranteed data duly stamped and signed by the Bidder.
- f. The Bid contains supplementary technical information to determine if each item offered meets the Technical Specifications of the Bidding Documents.

In the absence of substantial compliance with all of the above items, the bids are incomplete, shall be declared non-responsive and has to be rejected.



Step 3 – Opening of the Financial Offer

During the opening of the financial proposal, the following information is to be read and recorded:

- Name of Bidder;
- Any discount offered;
- Bid Security is in the form of Manager's Cheque only
- Bid security is present in the correct amount and acceptable form
- Validity of the Bid
- Net financial contracting capacity is computed
- ITR of the bidder for the past three (3) years duly marked received by the BIR is submitted
- Financial Statements of the bidder for the past three (3) years is submitted

a. The Bid contains price schedule(s) that have the unit price shown for each item in the completed bid schedule. The price schedule is to be checked for arithmetic errors in the extensions and the additions.

b. Determine that the Bidder has filled out correctly the price schedule for what he is bidding.

c. The price schedule be checked to determine that the correct quantities are shown.

d. Calculate the amounts for the applicable penalties as provided in the Technical Specifications and add amounts to the Bid prices for evaluation purposes only.

e. After the special factor, additions and conversion of schedule total to Philippine Peso, determine which remaining bid, has the lowest price for this bid schedule.

f. Compare the price of the low bid, for this bid schedule.

Step 4 - Evaluation and Comparison of Bids

All bids for this schedule are then financially evaluated to determine whether the company has the financial capability to perform the contract. Bidders who are found to be financially not sound shall be rejected.

If any item in the low bid has only minor technical deviations from the specifications, this shall be clarified with the bidder.

If any item in the low bid does not meet the technical specifications, that bid is rejected. The evaluation process then continues to the next low bid for that schedule.



This procedure to continue until the low bid, meeting the technical specifications of this Bidding Documents for this schedule, is determined.

Step 5 - Ability to Perform and Recommend for Award

After the low bid meeting the technical specifications is determined, check on enough of his previous sales of similar materials to determine whether the Bidder has demonstrated that he is qualified to perform the Contract. If the low Bidder is found to have provided unsatisfactory materials of similar nature on other contracts, his bid is to be rejected. The evaluation process then continues to the next low bid for that schedule.

This procedure shall continue until the low Bidder qualified to perform the contract for this schedule is determined. The recommendations for the Award of Contract for this schedule to this lowest responsible and responsive Bidder is automatic.

Note:

"Low bid" is hereby defined as the Bid on a complete bid schedule that has the lowest total price after considering all factors and/or reference up to that point in the evaluation procedure.



Table of Contents

SECTION	SUBJECT	PAGE NO.
	General Overview	0-1
I	Invitation to Bid	I-0
II	Instruction to Bidders	II-0
III	General Conditions of Contract	III-0
IV	Special Conditions of Contract	IV-0
V	General Technical Conditions	V-0
VI	Forms	VI-0
VII	Technical Specifications	VII-0



GENERAL OVERVIEW

This tender document is developed for the Construction of MCO Multi-Purpose Building. It is financed by the 2023 Approved Cash Operating Budget (COB) and made available to Nueva Ecija II Electric Cooperative, Inc.-Area 1 (NEECO II AREA-1). This ITB consists of:

- the invitation to bid;
- the necessary instruction to bidders;
- the general and special conditions of the policy/contract;
- the bid forms and pro-forma contract;
- the Price Schedules under Section VII are to be completed as applicable by the Bidder.

A checklist for the Bidders is attached to this General Overview as Annex A.

CHECKLIST OF ELIGIBILITY REQUIREMENTS

I. ELIGIBILITY REQUIREMENTS (Class "A" Documents)

A. LEGAL DOCUMENTS: FOLDER 1 (ENVELOPE 1)

- 1) DTI Business Name Registration/SEC Registration Certificate, whichever is appropriate under laws of the Philippines
- 2) Valid and Current Mayor's Permit/Municipal License (Principal Place of Business)
- 3) Taxpayer's Identification Number
- 4) BIR Value Added Tax Registration
- 5) Statement that the Bidder is not "Blacklisted" or banned from bidding by the government or any of its agencies, offices, corporation or LGUs, and other private corporations or electric cooperatives; including non-inclusion in the Consolidated Blacklisting Report issued by the Government Procurement Policy Board (GPPB), as provided in Section 69.4 of the IRR-A No. 9184
- 6) Compliance with E.O. # 398
 - a. Proof of VAT Payments for the past 6 months
 - b. Tax Clearance from the BIR to Prove Bidder's Full and Timely Payment of Taxes to the Government
 - c. A Certification under Oath from the Bidders Responsible Officers that the Bidder is Free and Clear of All Liabilities with the Government

B. TECHNICAL DOCUMENTS: FOLDER 2 (ENVELOPE 1)

- 1) Statement in Matrix Form all ongoing and completed government and private contracts (service contracts, maintenance contracts, purchase orders, job orders, etc.) within the relevant period, where applicable, including contracts awarded but not yet started, if any. The Statement shall state whether each contract is:
 - a. Ongoing, Completed or Awarded but not yet started; within the relevant period, where applicable. Each Contract should include the following:
 - i. The name of the Contract;
 - ii. Date of the Contract
 - iii. Amount of the Contract and Value of Outstanding Contracts;



- iv. Date of Delivery
- v. End-user's Acceptance, if completed

b. Similar or not similar in nature and complexity to the contract to be bid. For the procurement of goods, a contract shall be considered "similar" to the contract to be bid if it involves goods or related services of the same nature and complexity as those which are the subject of the public bidding is concerned.

- 2) PCAB License (Philippine Contractor's Accreditation Board) for Infrastructure Projects

C. FINANCIAL DOCUMENTS: FOLDER 3 (ENVELOPE 1)

- 1) Complete set of Audited Financial Statements, stamped "received" by the BIR or its duly accredited and authorized institutions, for the immediate preceding year, showing, among others the prospective bidder's total and current assets and liabilities.

Complete set of Financial Statement includes the following:

- 1. Balance Sheet
- 2. Income Sheet
- 3. Statement of Changes in Equity
- 4. Cash Flow Statement
- 5. Notes to Financial Statement
- 6. Statement of Management Responsibility for Financial Statement

- 2) The prospective Bidder's computation for its Net Financial Contracting Capacity (NFCC) or a commitment from a universal or commercial bank to extend to it a credit line if awarded the contract to be bid, in an amount not lower than that set by the procuring entity, which shall be as follows:

The computation of a prospective bidder's NFCC must be at least equal to the ABC to be bid which calculated as follows:

$NFCC = [(Current\ assets\ minus\ current\ liabilities)(K)]$ minus the value of all outstanding or uncompleted portions of the projects under ongoing contracts, including awarded contracts yet to be started, coinciding with the contract to be bid

Where:

$K = 10$ for a contract duration of one year or less, 15 for a contract duration of more than one year up to two years, and 20 for a contract duration of more than 2 years

CLASS "B" DOCUMENTS: FOLDER 4 (ENVELOPE 1)

- 1) Valid Joint venture Agreement, in case of joint venture. Each Member of the joint venture shall submit the required eligibility documents; and,
- 2) Letter authorizing the BAC or its duly authorized representative/s to verify any or all of the documents submitted for the eligibility check.



ITB NO. NE II-A1-2023-07

- 3) Notarized statement that each of the documents submitted in satisfaction of the eligibility requirements is an authentic and original copy, or a true and faithful reproduction or copy of the original, complete, and that all statements and information provided therein are true and correct.

D. BIDDER'S CHECKLIST: FOLDER 5 (ENVELOPE 1)

- 1) Eligibility and Source Statement for Bidder and Manufacturer
- 2) Power of Attorney
- 3) Letter of Authorization from the manufacturer to the Bidder/Trader to offer their material or equipment
- 4) Letter of Authorization from the Bidder to the Local Agent
- 5) Manufacturer and catalogue number of each offered item indicated
- 6) All additional data to be furnished by the bidder as per technical specifications
- 7) All deviations from the Specifications listed separately in the Form Deviation
- 8) All substitutions, if any, offered as an alternative Bid, clearly marked as such

II. BID PROPOSALS (ENVELOPE 2)

TECHNICAL PROPOSAL (FOLDER 1)

- 1) Bid Security as to form, amount and validity period
- 2) Authority of the Signatory
- 3) Confirming Statement of Delivery Schedule
- 4) Confirming Statement on Warranty Being Offered
- 5) Details of Technical Specification

FINANCIAL PROPOSAL (FOLDER 2)

- 1) Bid Prices in the prescribed bid form

- All pages and all changes initialled.
- Original and a Copy of all documents.



ANNEX A: BIDDER'S CHECKLIST

- Authorized signature on the Bid (Form 1).
- All pages and all changes initialled.
- Bid Security.
- Bid Summary.
- Bid Schedules completed.
- Bidder's Information.
- Eligibility and Source Statement for Bidder and Manufacturer.
- Bidders Qualification, Sales History and Financial Data.
- Power of Attorney.
- Letter of Authorization from the manufacturer to the Bidder/Trader to offer their material or equipment.
- Letter of Authorization from the Bidder to the Local Agent.
- Delivery Schedule duly signed.
- Technical Data Sheets properly filled in for each offered item and duly signed.
- Manufacturer and catalogue number of each offered item indicated.
- All additional data to be furnished by the bidder as per technical specifications.
- All deviations from the Specifications listed separately in the Form Deviations.
- All substitutions, if any, offered as an alternative Bid, clearly marked as such.
- Original and three copies of all documents.

In the absence of any of the above requirements, the bidder's offer is considered to be non-responsive with major deviation from the bidding documents.



NEECO II - AREA 1

NUEVA ECIJA II ELECTRIC COOPERATIVE, INC. - AREA 1

Calipahan, Talavera, Nueva Ecija
neeco2_area1@yahoo.com.ph
(044) 411-1007 loc. 117

ITB NO. NE II-A1-2023-07

SECTION I. INVITATION TO BID

NEECO II-AREA 1's Invitation to Bid No. NE-II-A1-2023-07

The Nueva Ecija II Electric Cooperative, Inc - Area 1 (NEECO II-Area 1) eligible Bidders for the following bidding activities based on Approved Annual Procurement Plan for the year 2023 and Board Resolution No. 09-04-23, Series of 2023

LOT	DESCRIPTION	ABC (Php) (VAT inclusive)	ACCREDITATION FEE (non-refundable)	BID DOCS FEE (non-refundable)
I	Construction of MCO Multi-Purpose Building	15,000,000.00	5,000.00	10,000.00

Schedule of bidding:

- SUBMISSION OF LETTER OF INTENT AND ACCREDITATION : September 27, 2023 (THRU EMAIL)
- PRE-BID CONFERENCE : October 6, 2023 (3:00PM)
- DEADLINE FOR SUBMISSION OF BIDS/BID OPENING : October 11, 2023 (3:00PM)

Participating bidders must be accredited by this Cooperative. Link for accreditation is available upon request to this email: bae_neeco2area1@yahoo.com.ph.

Only accredited bidders who paid accreditation fee and submitted Letter of Intent (LOI) shall receive the link for pre-bid conference. Participating bidders will pay bid documents prior to bid opening schedule.

Bidding document is available in electronic copy and will be posted in Coop's official website: www.neeco2area1.com to be downloaded by the bidders.

Further, a two percent (2%) of ABC bidder's bond is mandatory, which is to be returned immediately after the bid awarding.

NEECO II – Area 1 reserves the right to reject any or all bids, to waive any formality or technicality therein, to accept the bid that is deemed most advantageous and to annul the bidding process without incurring any liability to any bidder or party. Finally, NEECO II – Area 1 assumes no obligation to compensate any bidder or party for any loss or expense incurred in the preparation of the bid or participation in the bidding process.

For further inquiries, you may call (044)-411-1007 local 110 and/or email at bae_neeco2area1@yahoo.com.ph and look for Ms. Set Pauline Feliciano.

Ms. Marife Salvador, CPA, MBA
BAC Chair

Engr. Nelson M. Dela Cruz
General Manager



SECTION I. INVITATION TO BID

NEECO II-AREA 1's Invitation to Bid No. NE-II-A1-2023-07
 The Nueva Ecija II Electric Cooperative, Inc - Area 1 (NEECO II-Area 1) eligible Bidders for the following bidding activities based on Approved Annual Procurement Plan for the year 2023 and Board Resolution No. 09-04-23, Series of 2023

LOT	DESCRIPTION	ABC (Php) (VAT inclusive)	ACCREDITATION FEE (non-refundable)	BID DOCS FEE (non-refundable)
I	Construction of MCO Multi-Purpose Building	15,000,000.00	5,000.00	10,000.00

Schedule of bidding:

- SUBMISSION OF LETTER OF INTENT AND ACCREDITATION : September 27, 2023 (THRU EMAIL)
- PRE-BID CONFERENCE : October 6, 2023 (3:00PM)
- DEADLINE FOR SUBMISSION OF BIDS/BID OPENING : October 11, 2023 (3:00PM)

Participating bidders must be accredited by this Cooperative. Link for accreditation is available upon request to this email: bac_neeco2area1@yahoo.com.ph

Only accredited bidders who paid accreditation fee and submitted letter of intent (LOI) shall receive the link for pre-bid conference. Participating bidders will pay bid documents prior to bid opening schedule.

Bidding document is available in electronic copy and will be posted in Coop's official website: www.neeco2area1.com to be downloaded by the bidders.

Further, a two percent (2%) of ABC bidder's bond is mandatory, which is to be returned immediately after the bid awarding.

NEECO II - Area 1 reserves the right to reject any or all bids, to waive any formality or technicality therein, to accept the bid that is deemed most advantageous and to annul the bidding process without incurring any liability to any bidder or party. Finally, NEECO II - Area 1 assumes no obligation to compensate any bidder or party for any loss or expense incurred in the preparation of the bid or participation in the bidding process.

For further inquiries, you may call (044)-411-1007 local 110 and/or email at bac_neeco2area1@yahoo.com.ph and look for Ms. Set Pauline Feliciano.

 Ms. Marife Salvador, CPA, MBA
 BAC Chair

 Engr. Nelson M. Dela Cruz
 General Manager

**SECTION III. GENERAL CONDITIONS OF CONTRACT****TABLE OF CLAUSES**

CLAUSE	TOPIC	Page Number
1	Definitions	III - 1
2	Application	III - 1
3	Country of Origin	III - 1
4	Standards	III - 2
5	Use of Contract Documents and Information	III - 2
6	Patent Rights	III - 2
7	Performance Security	III - 2
8	Inspections and Tests	III - 3
9	Packing and Marking	III - 4
10	Delivery and Documents	III - 4
11	Safety	III - 4
12	Insurance	III - 5
13	Transportation	III - 5
14	Incidental Services	III - 5
15	Spare Parts	III - 6
16	Warranty	III - 6
17	Payment	III - 7
18	Prices	III - 7
19	Change Orders	III - 8
20	Contract Amendments	III - 8
21	Assignment	III - 8
22	Delays in the Contractor's Performance	III - 8
23	Liquidated Damages	III - 8
24	Termination for Defaults	III - 9
25	Force Majeure	III - 9
26	Termination for Insolvency	III - 8
27	Termination for Convenience	III - 8
28	Resolution of Disputes	III - 9
29	Governing Language	III - 10
30	Applicable Law	III - 11
31	Notices	III - 11
32	Taxes and Duties	III - 11



1. DEFINITIONS

1.1 In this contract the following terms shall be interpreted as indicated:

- (a) "The Contract" means the agreement entered into between the Procuring Entity and the Contractor, as recorded in the Contract Form signed by the parties, including all attachments and appendices thereto and all documents incorporated by reference therein.
- (b) "The Contract Price" means the price payable to the Contractor under the Contract for the full and proper performance of its contractual obligations;
- (c) "The Goods" means all of the equipment, machinery and/or other materials which the Contractor is required to supply to the Procuring Entity under the Contract;
- (d) "Services" means services ancillary to the supply of the Goods, such as transportation and insurance, and any other incidental services, such as installation, commissioning, provision of technical assistance, training and other such obligations of the Contractor covered under the Contract;
- (e) "The Procuring Entity" means the Nueva Ecija II Electric Coop., Inc. Area 1
- (f) "The Contractor" means the individual or firm supplying the Goods under this Contract;

2. APPLICATION

These General Conditions shall apply as part of the Contract which shall include the following documents and the priority of these documents shall be as follows:

- a) Contract Agreement
- b) Notification of Award
- c) Special Conditions of Contract
- d) General Conditions of the Contract
- e) Bidding Documents
- f) Forms and Schedules
- g) Contractor's Bid

3. COUNTRY OF ORIGIN

3.1 All Goods and Services supplied under the Contract shall have their origin from the eligible source countries, as defined in Section II, Clause 3.



ITB NO. NE II-A1-2023-07

- 3.2 For purposes of this Clause 3, "origin" means the place where the Goods were mined, grown or produced, or from which the services are supplied. Goods are produced when, through manufacturing, processing, or substantial and major assembling of components, a commercially recognized new product results that is substantially different in basic characteristics or in purpose or utility from its components.
- 3.3 The origin of Goods and Services is distinct from the nationality of the Contractor.

4. STANDARDS

- 4.1 The Goods supplied under this Contract shall conform to the standards mentioned in the Technical Specifications, and, when no applicable standard is mentioned, to the authoritative standard appropriate to the Goods' country of origin and such standards shall be the latest issued by the concerned institution.

5. USE OF CONTRACT DOCUMENTS AND INFORMATION

- 5.1 The Contractor shall not, without the Procuring Entity's prior written consent, disclose the Contract, or any provision thereof, or any specification, plan, drawing, pattern, sample or information furnished by or on behalf of the Procuring Entity in connection therewith, to any person other than a person employed by the Contractor in the performance of the Contract. Disclosure to any such employed person shall be made in confidence and shall extend only as far as may be necessary for purposes of such performance.
- 5.2 The Contractor shall not, without the Procuring Entity's prior written consent make use of any document or information enumerated in paragraph 5.1 except for purposes of performing the Contract.
- 5.3 Any document, other than the Contract itself, enumerated in paragraph 5.1 shall remain the property of Procuring Entity and shall be returned (in all copies) to the Procuring Entity on completion of the Contractor's performance under the Contract if so required by the Procuring Entity.

6. PATENT RIGHTS

- 6.1 The Contractor shall indemnify the Procuring Entity against all third-party claims of infringement of patent, trademark or industrial design rights arising from use of the Goods or any part thereof in the Philippines.

7. PERFORMANCE SECURITY

- 7.1 Within five (5) working days after the Contractor's receipt of notification of award of the Contract, the Contractor shall furnish performance security to the Procuring Entity in the amount specified in the Special Conditions of Contract.
- 7.2 The proceeds of the Performance Security shall be payable to the Procuring Entity as compensation for any loss resulting from the Contractor's failure to complete its obligations under the Contract. The performance security shall be to the account of



ITB NO. NE II-AI-2023-07

the Contractor who signed the Contract. The performance security shall also guarantee the enforcement of the warranty provision in Clause 16 of this section.

- 7.3 The Performance Security, which should be callable on demand shall be denominated in the currency of the Contract and shall be in one of the following forms:
- (a) A bank guarantee or irrevocable Letter of Credit, issued by a bank in the Philippines or a bank abroad which has a jointly and severally liable correspondent bank in the Philippines, acceptable to the Procuring Entity, and in the form provided in the Bidding Documents or another form acceptable to the Procuring Entity. The Procuring Entity may request that said bank guarantee or irrevocable Letter of Credit be confirmed by a reputable bank acceptable to the EC.
- Or
- (b) A cashier's check, certified check, or cash.
- 7.4 The performance security will be discharged by the Procuring Entity and returned to the Contractor not later than thirty (30) days following the date of completion of the Contractor's performance obligations, including any warranty obligation, under the Contract.

8. INSPECTIONS AND TESTS

- 8.1 The Procuring Entity or its designated third party inspector shall, at all reasonable times, be allowed free and ready access to the Contractor's premises and those of his sub-contractors for the purpose of inspecting the specified goods and obtaining information as to the progress of the work.
- 8.2 The Procuring Entity or its designated third party inspector shall have the right to inspect and/or to test the Goods to confirm their conformity to the Contract. The Special Conditions of Contract and/or the Technical Specifications shall specify what inspections and tests the Procuring Entity requires and where they are to be conducted. The Procuring Entity shall notify the Contractor in writing of the identity of any representatives retained for these purposes.
- 8.3 The inspections and tests may be conducted on the premises of the Contractor or its sub-contractor(s), at point of delivery and/or at the good's final destination. Where conducted on the premises of the Contractor or its sub-contractor(s), all reasonable facilities and assistance-including access, drawings and production data-shall be furnished two weeks before such tests take place to the inspectors at no charge to the Procuring Entity
- 8.4 Should any inspected or tested Goods fail to conform to the Specification, the Procuring Entity may reject them, and the lot they represent, and the Contractor shall replace the rejected Goods within the life of the Contract or not later than ninety (90) days from receipt of notice of rejection, whichever comes first, or all alterations



ITB NO. NE II-A1-2023-07

necessary to meet specification requirements free of cost to the Procuring Entity

- 8.5 The Procuring Entity's right to inspect, test and, where necessary, reject the Goods after the Goods' arrival in the Philippines shall in no way be limited or waived by reason of the Goods having previously been inspected, tested and passed by the Procuring Entity or its representative prior to the Goods shipment from the country of origin.
- 8.6 Test Certificates for all Goods shall be prepared by the Contractor, signed by both the Contractor and the Procuring Entity or third party inspectors. Also in case of no attendance of the tests by the Procuring Entity or third party inspector, test certificates signed by the Contractor are to be submitted to the Procuring Entity.
- 8.7 Nothing in Clause 8 shall in any way release the Contractor from any warranty or other obligations under this Contract.

9. PACKING AND MARKING

- 9.1 The Contractor shall provide such packing of the Goods as is required to prevent their damage or deterioration during transit to their final destination as indicated in the Special Conditions of Contract. The packing shall be sufficient to withstand, without limitation, rough handling during transit and exposure to extreme temperatures, salt and precipitation during transit and open storage. Packing case size and weights shall take into consideration, where appropriate, the remoteness of the Goods' final destination and the absence of heavy handling facilities at all points in transit.
- 9.2 The packing, marking and documentation within and outside the package shall comply strictly with such special requirements as shall be expressly provided for in the Contract and, subject to Clause 18, in any subsequent instructions ordered by the Procuring Entity.
- 9.3 Proposal for packing and marking should be approved by the Procuring Entity.

10. DELIVERY AND DOCUMENTS

- 10.1 Delivery of the Goods shall be made by the Contractor in accordance with the terms specified by the Procuring Entity in its Schedule of Requirements and Special Conditions of Contract.
- 10.2 For purposes of the Contract, "FOB", "CIF" and other trade terms used to describe the obligations of the parties shall have the meanings assigned to them by the current edition of the International Rules for the Interpretation of the Trade Terms published by the International Chamber of Commerce, Paris, and commonly referred to as INCOTERMS.

11. SAFETY

- 11.1 The contractor shall adhere to all safety protocols and procedures at all time to include



but not limited to:

- (a) Having safety officer/s available at any time of the day during construction;
- (b) Providing safety equipment and other necessary personal protective equipment (PPE) to all workers, and ensure that they wear those PPEs whenever on site; and,
- (c) All other workplace safety protocols as required by the DOLE

12. INSURANCE

12.1 The Goods supplied under the Contract shall be fully insured in the currency of the contract against loss or damage incidental to manufacture or acquisition, transportation, storage and delivery in the manner specified in the Special Conditions of Contract.

13. TRANSPORTATION

13.1 Where the Contractor is required to effect delivery under any other terms, for example, by post or another address in the source country, the Contractor shall be required to meet all transport and storage expenses until delivery.

13.2 In all of the above cases, transportation of the Goods after delivery at the designated point of delivery shall be the responsibility of the Procuring Entity.

13.3 Ocean transportation shall be by vessels registered in eligible source countries, as defined in Clause 3 of the Instructions to Bidders, or belonging to shipping conferences in which shipping lines from such member countries hold the major share.

14. INCIDENTAL SERVICES

14.1 As specified in the Special Conditions of Contract, the Contractor may be required to provide any or all of the following services:

- (a) Performance or supervision of on-site assembly and/or start-up of the supplied Goods;
- (b) Furnishing of tools required for assembly and/or maintenance of the supplied Goods;
- (c) Furnishing of a detailed operations and maintenance manual for each appropriate unit of the supplied Goods;
- (d) Performance or supervision or maintenance and/or repair of the supplied Goods, for a period of time agreed by the parties, provided that this service shall not relieve the Contractor of any warranty obligations under this Contract; and
- (e) Conduct of training of the Procuring Entity's personnel, at the Contractor's plant and/or on-site, in assembly, start-up, operation, maintenance and/or repair of the supplied Goods.



- 14.2 Prices charged by the Contractor for the preceding incidental services, if not included in the Contract Price for the Goods, shall be agreed upon in advance by the parties and shall not exceed the prevailing rates charged by the Contractor to other parties for similar services.

15. SPARE PARTS

- 15.1 As specified in the Special Conditions of Contract, the Contractor may be required to provide any or all of the following materials and notifications pertaining to spare parts manufactured or distributed by the Contractor:

- (a) Such spare parts as the Procuring Entity may elect to purchase from the Contractor, provided that this election shall not relieve the Contractor of any warranty obligations under the Contract; and
- (b) In the event of termination of production of the spare parts:
 - (i) advance notification to the Procuring Entity of the pending termination, in sufficient time to permit the Procuring Entity to procure needed requirements; and
 - (ii) following such termination, furnishing at no cost to the Procuring Entity, the blue prints, drawings, and specifications of the spare parts, if and when requested.

16. WARRANTY

- 16.1 The Contractor warrants that the Goods supplied under the Contract are new, unused, of the most recent or current models and incorporate all recent improvements in design and materials unless provided otherwise, in the Contract. The Contractor further warrants that the Goods supplied under this Contract shall have no defect arising from design, materials or workmanship or from any act or omission of the Contractor that may develop under normal use of the supplied Goods in the conditions obtaining in the country of final destination.
- 16.2 This warranty shall remain valid for 12 months after the Goods or any portion thereof as the case maybe, have been delivered to the final destination and commissioned indicated in the Contract or for 18 months after the date of shipment to the port of entry in the Philippines, whichever period concludes earlier, unless specified otherwise in the Special Conditions of Contract or in the Technical Specifications.
- 16.3 The Procuring Entity shall promptly notify the Contractor in writing of any claims arising under this warranty.
- 16.4 Upon receipt of such notice, the Contractor shall repair or replace within 30 days of such notification the defective Goods or part thereof, without costs to the Procuring Entity other than, where applicable, the cost of inland delivery of the repaired or



ITB NO. NE II-A1-2023-07

replace Goods or parts from the port of entry to the final destination.

- 16.5 If the Contractor, having been notified, fails to remedy the defect(s) within 30 days of such notification, the Procuring Entity may proceed to take such remedial action as may be necessary, at the Contractor's risk and expense and without prejudice to any other rights which the Procuring Entity may have against the Contractor under the Contract.
- 16.6 In case the Contractor fails to undertake the repair works, the Procuring Entity shall forfeit its performance security and perpetually disqualify it from participating in any public bidding.

17. PAYMENT

- 17.1 The method and conditions of payment to be made to the Contractor under the Contract shall be specified in the Special Conditions of Contract.
- 17.2 The currency in which payment is made to the Contractor under this Contract shall be specified in the Special Conditions of Contract.
- 17.3 No payment shall be due while the Contractor is in default in respect to any of the provisions of the contract. On the event that the Contractor is in default, the Procuring Entity reserve the right to instruct Procuring Entity designated bank to withhold any or all payments.

18. PRICES

- 18.1 Prices charged by the Contractor for Goods delivered and Services performed under the Contract shall not, with the exception of any price adjustments authorized by the Special Conditions of Contract, vary from the prices quoted by the Contractor in its bid.

19. CHANGE ORDERS

- 19.1 The Procuring Entity may at any time, by a written order given to the Contractor pursuant to Clause 31, General Conditions of Contract, make changes within the general scope of the Contract in any one or more of the following:
- (a) drawings, designs or specifications where Goods to be furnished under the Contract are to be specifically manufactured for the Procuring Entity;
 - (b) the method of shipment or packing;
 - (c) place of delivery; or
 - (d) the Services to be provided by the Contractor.
- 19.2 If any such change causes an increase or decrease in the cost of, or the time required for, the Contractor's performance of any part of the work under the Contract whether



ITB NO. NE II-A1-2023-07

changed or not changed by the order, an equitable adjustment shall be made to the Contract Price or delivery schedule, or both, and the Contract shall accordingly be amended. Any claims by the Contractor for adjustment under this clause must be asserted within thirty (30) days from the date of the Contractor's receipt of the Procuring Entity's change order.

20. CONTRACT AMENDMENTS

20.1 Subject to Clause 19, no variation or modification of the terms of the Contract shall be made except by written amendments signed by the parties.

21. ASSIGNMENT

21.1 The Contractor shall not assign, in whole or in part, its obligations to perform under the Contract, except with the Procuring Entity's prior written consent.

22. DELAYS IN THE CONTRACTOR'S PERFORMANCE

22.1 Delivery of the Goods and performance of Services shall be made by the Contractor in accordance with the time schedule specified by the Procuring Entity in its Schedule of Requirements.

22.2 A delay by the Contractor in the performance of its delivery obligations, for which either no amendment to the contract or no extension of the performance security was made, shall render the Contractor liable to any or all of the following sanctions:

22.2.1 forfeiture of its performance security,

22.2.2 imposition of liquidated damages,

22.2.3 and/or termination of the Contract for default.

22.3 If at any time during performance of the Contract, the Contractor or its sub-contractor(s) should encounter conditions impeding timely delivery of the Goods and performance of the Services, the Contractor shall promptly notify the Procuring Entity in writing of the fact of the delay, its likely duration and its cause(s). As soon as practicable after the receipt of the Contractor's notice, the Procuring Entity shall evaluate the situation and may at its discretion extend the Contractor's time for performance, in which case the extension shall be ratified by the parties by amendment of the Contract.

23. LIQUIDATED DAMAGES

23.1 Subject to Clause 25, if the Contractor fails to secure acceptance from the Procuring Entity for the delivery of any or all of the Goods or performance of the Services within the delivery period(s) specified in the Contract, the Procuring Entity shall, without prejudice to its other remedies under the Contract, deduct from the Contract Price, as liquidated damages, a sum equivalent to one tenth of one percent (0.1 %) of the delivered price of the Goods or Services that were delivered early or delayed, for



ITB NO. NE II-A1-2023-07

each day outside of the Contract schedule for deliveries, up to a maximum deduction of Ten (10%) percent of the Contract Price of the Goods or Services involved. Once the maximum is reached, the Procuring Entity may consider termination of the Contract.

24. TERMINATION FOR DEFAULT

- 24.1 The Procuring Entity may, without prejudice to any other remedy for breach of contract, by written notice of default sent to the Contractor, terminate the Contract in whole or in part:
- (a) If the Contractor fails to deliver any or all of the Goods within the time period(s) specified in the Contract, or any extension thereof granted by the Procuring Entity; or
 - (b) If the Contractor fails to perform any other obligation(s) under the Contract.
- 24.2 In the event the Procuring Entity terminate the Contract in whole or in part, pursuant to paragraph 24.1, the Procuring Entity may procure, upon such terms and in such manner as it deems appropriate, Goods similar to those undelivered, and the Contractor shall be liable to the Procuring Entity for any additional cost of Goods for such similar Goods. However, the Contractor shall continue performance of the Contract to the extent not terminated.

25. FORCE MAJEURE

- 25.1 Notwithstanding the provisions of Clause 23 and 24, the Contractor shall not be liable for forfeiture of its performance security, liquidated damages or termination for default, if and to the extent that, its delay in performance or other failure to perform its obligations under the Contract is the result of an event of Force Majeure.
- 25.2 For purposes of this clause, "Force Majeure" means an event beyond the control of the Contractor and not involving the Contractor's fault or negligence and not foreseeable. Such events may include, but not restricted to wars or revolution, fires, floods, epidemics, quarantine restrictions and freight embargoes.
- 25.3 If a Force Majeure situation arises, the Contractor shall promptly notify the Procuring Entity in writing of such condition and the cause thereof. Unless otherwise directed by the Procuring Entity in writing, the Contractor shall continue to perform its obligations under the Contract as far as is reasonably practical, and shall seek all reasonable alternative means for performance not prevented by the Force Majeure event.



26. TERMINATION FOR INSOLVENCY

- 26.1 The Procuring Entity may at any time terminate the Contract by giving written notice to the Contractor, without compensation to the Contractor, if the Contractor becomes bankrupt or otherwise insolvent. Notwithstanding the above, such termination will not prejudice or affect any right of action or remedy which has accrued or will accrue thereafter to the Procuring Entity.

27. TERMINATION FOR CONVENIENCE

- 27.1 The Procuring Entity may, by written notice sent to the Contractor, terminate the Contract, in whole or in part, at any time for its convenience. The notice of termination shall specify that termination is for the Procuring Entity's convenience, the extent to which performance of work under the Contract is terminated, and the date upon which such termination becomes effective.
- 27.2 The Goods that are complete and ready for shipment within thirty (30) days after the Contractor's receipt of notice of termination shall be purchased by the Procuring Entity at the Contract terms and prices. For the remaining Goods, the Procuring Entity may elect:
- (a) to have any portion completed and delivered at the Contract terms and prices; and/or
 - (b) to cancel the remainder and pay to the Contractor an agreed amount for partially completed Goods and for materials and parts previously procured by the Contractor for the use in this contract.

28. RESOLUTION OF DISPUTES

- 28.1 The Procuring Entity and the Contractor shall make every effort to resolve amicably by direct informal negotiation any disagreement or dispute arising between them under or in connection with the Contract.
- 28.2 If, after thirty (30) days from the commencement of such informal negotiations, the Procuring Entity and the Contractor have been unable to resolve amicably a Contract dispute, either party may require that the dispute be referred for resolution to the formal mechanism specified in the Special Conditions of Contract. This mechanism may include, but is not restricted to, conciliation mediated by a third party, adjudication in an agreed national or international forum, and/or international arbitration. The mechanism shall be specified in the Special Conditions of Contract.

29. GOVERNING LANGUAGE

- 29.1 The Contract shall be written in the language of the bid, as specified by the Procuring Entity in the Instruction to Bidders. Subject to Clause 30, the language version of the Contract shall govern its interpretation. All correspondence and other documents pertaining to the Contract which are exchanged by the parties shall be written in that same language.



30. APPLICABLE LAW

30.1 The Contract shall be interpreted in accordance with the laws of the Philippines.

31. NOTICES

31.1 Any notice given by one party to the other pursuant to the Contract shall be sent in writing or by telegram, fax or telex/cable and confirmed in writing to the address specified for that purpose in the Special Conditions of Contract.

31.2 A notice shall be effective when delivered or on the notice's effective date, whichever is later.

32. TAXES AND DUTIES

32.1 A Contractor providing imported goods shall be entirely responsible for all taxes, stamp duties, license fees, and other such levies imposed outside the Philippines.

32.2 A Contractor providing domestic goods shall be entirely responsible for all taxes, duties, license fees, etc., incurred until delivery of the Contract Goods to the Procuring Entity. Value Added Tax (VAT) or similar local taxes on finished products shall be identified and shall be reimbursed to the Contractor by the Procuring Entity upon presentation of documentary evidence that taxes have been paid (Clause 11.2.3, Section IV - Special Conditions of Contract).



SECTION IV. SPECIAL CONDITIONS OF CONTRACT

TABLE OF CLAUSES

CLAUSE NUMBER	TOPIC	PAGE NUMBER
1	General	IV - 1
2	Definitions	IV - 1
3	Country of Origin	IV - 1
4	The Contractor's Obligations	IV - 1
5	Performance Security	IV - 1
6	Inspection and Test	IV - 1
7	Packing and Marking	IV - 2
8	Delivery and Documents	IV - 2
9	Insurance	IV - 5
10	Incidental Services	IV - 5
11	Spare Parts	IV - 5
12	Liability of the Contractor	IV - 5
13	Termination for other Causes	IV - 5
14	Payment	IV - 6
15	Resolution of Disputes	IV - 7
16	Notices	IV - 7



1. GENERAL

The following Special Conditions of Contract shall supplement the General Conditions of Contract. Whenever there is a conflict, the provisions herein shall prevail over those in the General Condition of Contract. The corresponding clause number of the General Condition is indicated in parenthesis.

2. DEFINITION

2.1 The Procuring Entity is Nueva Ecija II Electric Cooperative., Inc.- Area 1

2.2 The Contractor is (Name of Contractor)

2.3 EC or Coop is Electric Cooperative

3. COUNTRY OF ORIGIN

3.1 The countries of origin are defined in Section II, Clause 3.1, whereas the term "origin" is defined in Section III, Clause 3.

4. THE CONTRACTOR'S OBLIGATIONS

4.1 The Contractor shall employ the key personnel named in the Schedule of Key Personnel indicating their designation, to carry out the supervision of the Works.

4.2 The Procuring Entity will approve any proposed replacement of key personnel only if their relevant qualifications and abilities are equal to or better than those of the personnel listed in the Schedule.

5. PERFORMANCE SECURITY

The Performance Security shall be in the amount of ten (10%) percent in the form of Manager's Check.

5.1 shall be valid initially for a period covering the delivery and construction work schedule plus 90 calendar days; and

5.2 shall be extended to cover also the warranty period of the delivered goods/construction within one (1) year.

6. INSPECTION AND TEST

The inspection and test procedures, required by the Procuring Entity, are described in Section V - General Technical Conditions as well as in Section VII - Technical Specifications.



Cost for a minimum of two (2) Procuring Entity's representative(s), such as travel cost, accommodation and living expenses shall be borne by the Contractor.

7. PACKING AND MARKING

7.1 Refer to Section V, Clause 9 and 10, for marking requirement.

8. DELIVERY AND DOCUMENTS

8.1 Delivery Schedule:

For goods supplied within the Philippines counting will be from the date the Supply Contract is signed.

Delivery is considered complete when:

- a) the specified quantity of goods are received at the Coops Headquarters or as specified by the Procuring Entity within the area coverage in accordance with all the requirements in the contract, or
- b) the goods, to be delivered, at Manila warehouse/factory, have been loaded on the Contractor's truck, or
- c) the goods, to be delivered to the Coop headquarters or as specified by the Procuring Entity within the area coverage, have been received by the Coop and a Receiving Report has been provided by the Coop.

8.2 Documents for Imported Goods Shipped to EC HQ.

Upon shipment, the Contractor shall notify the Procuring Entity and the Insurance Company by cable, fax or telex the full details of the shipment including Contract number, description of Goods, quantity, vessel, the bill of lading number and date, port of loading, date of shipment, port of discharge, estimated time of arrival, port of entry, etc. The Contractor shall send by courier the following documents to the Procuring Entity with a copy to the Insurance Company:

- 8.2.1 Original & certified true copy of the Contractor's invoice showing Goods description, quantity, unit price, total amount. The cost of insurance and freight included in the total amount shall be itemized separately. The cost of inland freight, brokerage, handling and other incidental expenses within the Philippines, included in the total amount shall likewise be itemized separately.
- 8.2.2 Original and certified true copy of the negotiable, clean on-board bill of lading of the final carrier/vessel to Philippines marked freight



- prepaid and two (2) copies of non-negotiable bill of lading;
- 8.2.3 Original & certified true copy of packing list identifying contents of each package by serial number;
- 8.2.4 Original & certified true copy of Insurance Certificate;
- 8.2.5 Original & certified true copy of Manufacturer's/Contractor's guarantee certificate;
- 8.2.6 Original & certified true copy of:
- 8.2.6.1 Inspection certificate issued by the EC or any authorized inspection agency or a certificate of waiver signed by the EC;
- 8.2.6.2 the Manufacturer's factory inspection report, and
- 8.2.6.3 Societe de Surveillance (SGS) pre-shipment Clean Report of Findings or number and date of issue.
- 8.2.7 Original & a certified true copy Certificate of Origin endorsed by the Chamber of Commerce.
- 8.2.8 Original & certified true copy of evidence showing that the Contractor has forwarded the shipping documents listed above to the Procuring Entity via an international document handling service similar to Federal Express or DHL. These documents shall reach the Procuring Entity not later than ten (10) calendar days after shipment as evidenced by the date of the Bill of Lading, except those shipping documents covering shipment of materials from Japan, Korea, Taiwan, Thailand and other eligible Asian source countries and airshipments, which shall reach the Procuring Entity not later than three (3) calendar days after shipment. Any expenditure incurred by the Procuring Entity (such as demurrage charges, storage fee, document reproduction costs and other similar charges/expenditure) as result of late receipt of required shipping documents, or incorrect shipping documents, shall be for the account of the Contractor. Filing fee being charged by the BOI, DOF and other government agencies for the tax and duty free importation of the goods shall be borne by the Contractor.
- 8.2.9 Original & a certified true copy of the extension for the Performance Security as per Clause 5.2.
- 8.3 Documents for Domestic Goods delivered to EC HQ.



The Contractor shall send the following documents to the EC with a copy to each the Procuring Entity and the insurance company:

- 8.3.1 Original & certified true copy of the Contractor's invoice showing Goods description, quantity, unit price, total amount. The cost of freight from Contractor's Warehouse to designated destination shall be itemized separately.
- 8.3.2 Original & certified true copy of packing list identifying contents of each package by serial number, Consignee & recipient Coop.
- 8.3.3 Original & certified true copy of Insurance Certificate on any Goods shipped DDP to EC HQ.
- 8.3.4 Original & certified true copy of Manufacturer's/Contractor's guarantee certificate;
- 8.3.5 Original & certified true copy of Inspection certificate issued by:
 - 7.3.5.1 An authorized inspection agency or a certificate of waiver signed by the EC, and
 - 7.3.5.2 the Manufacturer's factory inspection report.
- 8.3.6 Original & certified true copy of Certificate of Origin.
- 8.3.7 For wood products, a copy of the DENR logging permit under which the trees were cut in the Philippines.
- 8.3.8 Original & certified true copy of the extension for the Performance Security as per Clause 5.2.
- 8.3.9 Original & certified true copy of the certificates proving the amount for all costs as well as duties and taxes paid or payable on components and raw material incorporated or to be incorporated in the goods as stated in the price sheets.

Payments are limited to the amount stated in such certificates but shall not exceed the amount stated in the price sheets."

9. INSURANCE

The marine and inland insurance shall be in an amount equal to one hundred ten percent (110%) of the value of the Goods from "warehouse to recipient EC warehouse" on "All Risks" basis including War Risk, Civil Unrest, and Strike clauses and shall be valid for ninety (90) days after arrival of the equipment at designated EC HQ or as specified by the Procuring Entity within the area coverage.



The insurance shall be paid by the Contractor. It shall be the responsibility of the Contractor that the insurance coverage provided include the cost of conducting all necessary investigation of report of damage, loss or pilferage. Such investigation and preparation of report shall be done by the Contractor at no cost to the Procuring Entity.

10. INCIDENTAL SERVICES

The services covered under Clause 13, Section III, General Conditions of Contract, Sub-Clause 13.1 letters (c), (d), and that of those required in the Technical Specifications shall be furnished. The cost shall be included in the contract price.

11. SPARE PARTS

Contractors shall carry sufficient inventories to assure ex-stock supply of consumable spares such as gaskets, plugs, washers, belts, etc. other spare parts and components shall be supplied as promptly as possible but in any case shall not exceed one (1) month after placement of order and establishment of Letter of Credit or execution of Contract.

12. Liability of the Contractor

If the Contractor is a joint venture, all partners to the joint venture shall be jointly and severally liable to the Procuring Entity.

13. Termination for Other Causes

Contract termination shall be initiated in case it is determined *prima facie* by the Procuring Entity that the Contractor has engaged, before, or during the implementation of the contract, in unlawful deeds and behaviors relative to contract acquisition and implementation, such as, but not limited to corrupt, fraudulent, collusive, coercive, and obstructive practices.

14. PAYMENT

11.1 For Goods and services supplied from countries other than the Philippines payment shall be made as follows:

11.1.1 Once a month or for an accomplishment of at least P 1.0 million, the contractor may submit a request for payment for work accomplished. Such request for payment shall be verified and certified by the Coop project engineer, and approved by Coop Technical/Engineering Manager. Except as otherwise stipulated in the contract, materials and equipment delivered on the site but not completely put in place shall not be included for payment.

11.1.2 The Coop shall have the right to deduct from the contractor's progress billing such amount as may be necessary to cover third



party liabilities, as well as uncorrected discovered defect in the project.

11.2 For Goods and Services supplied from within the Philippines, payment shall be made as follows:

11.2.1 Once a month or for an accomplishment of at least P 1.0 million, the contractor may submit a request for payment for work accomplished. Such request for payment shall be verified and certified by the Coop project engineer, and approved by Coop Technical/Engineering Manager. Except as otherwise stipulated in the contract, materials and equipment delivered on the site but not completely put in place shall not be included for payment.

11.2.2 The Coop shall have the right to deduct from the contractor's progress billing such amount as may be necessary to cover third party liabilities, as well as uncorrected discovered defect in the project.

11.3 Should the Contractor fail to receive from Procuring Entity the Acceptance Certificate as specified in paragraphs 11.1.2 & 11.2.2 within (60) days following the date of delivery of the materials to Procuring Entity headquarters or as specified by the Procuring Entity within the area coverage, the Contractor may request for payment by submitting to Procuring Entity three (3) copies of the Voucher bearing the following certification:

I/we hereby certify that the materials and equipment covered by this invoice were delivered to the Procuring Entity headquarters or as specified by the Procuring Entity delivery point as specified in the Delivery Schedule prior to sixty (60) days before the date of this certification, that all warranties and guaranties, and final drawing have been delivered to Procuring Entity, that no objection of any kind has been received from Procuring Entity to the payment of the remaining ten (10%) percent of this equipment.

_____ Date

_____ Contractor

ATTESTED BY:

_____ Authorized Signature

_____ Title



15. RESOLUTION OF DISPUTES

The dispute resolution mechanism to be applied pursuant to Clause 28 of the General Conditions shall be as follows:

- 12.1 in the case of a dispute between the Procuring Entity and a Contractor which is a national of the Philippines, the dispute shall be referred to adjudication/arbitration in accordance with the laws of the Philippines; and
- 12.2 in the case of a dispute between the Procuring Entity and a foreign Contractor, the dispute shall be settled by arbitration, held in Manila, in accordance with the provisions of the UNCITRAL Arbitration Rule

16. NOTICES

For the purpose of all notices, the following shall be the address of the Procuring Entity and Contractor.

Procuring Entity:

Ms. Marife T. Salvador
BAC Chairman
Nueva Ecija II Electric Cooperative, Inc.-Area 1 (NEECO II Area 1)
Calipahan, Talavera, Nueva Ecija
Philippines 3114
Tel./Fax 044 411 1007
e-mail: bac_necco2area1@yahoo.com.ph

Contractor:

(to be filled in at the time of contract signature)



SECTION V. GENERAL TECHNICAL CONDITIONS

TABLE OF CLAUSES

CLAUSE NUMBER	TOPIC	PAGE NUMBER
1	Form of Specifications	V - 1
2	Submittal of Information	V - 1
3	Codes and Standards	V - 3
4	Special Tools	V - 4
5	Structural Tests	V - 4
6	Factory Test and Inspection	V - 5
7	Defective Equipment and Materials	V - 5
8	Export Packing	V - 6
9	Export Marking	V - 7
10	Sag and Tension Tables	V - 9
11	Qualified Manufacturers	V - 10
12	Standards and Specifications	V - 10
13	Material Specifications Listing	V - 18



1. FORM OF SPECIFICATIONS

- 1.1 Abbreviated, outline type.
- 1.2 Determine components of specifications from Table of Contents.

2. SUBMITTAL OF INFORMATION

- 2.1 General: After award of Contract, submit information requested herein to location designated. All information shall be in English.
- 2.2 Updated Delivery Schedule:
Submit three (3) copies. (See Section IV)
- 2.3 Shipping Papers:
Submit three (3) copies, unless specified otherwise, of reports required in specifications and required by referenced codes and standards.
- 2.4 Test Reports:
Submit three (3) copies unless specified otherwise, of reports required in specifications and required by referenced codes and standards.
- 2.5 Instruction Manuals:
Submit two (2) complete sets of instruction manuals for each unit supplied; covering installation, operation and maintenance for equipment, auxiliary items and accessory devices furnished, and including assembly drawings descriptive literature and parts lists, with identification symbols, for all replaceable parts and assemblies including address, phone and fax number where spare parts shall be ordered.
 - 2.5.1 Instruction manuals shall include nameplate information and shop order numbers for each item of equipment furnished.
 - 2.5.2 Instruction manuals shall include a list of recommended spare parts.
 - 2.5.3 Information manual shall be bound between hard covers and the contents shall be properly indexed.
- 2.6 Shop drawings and manufacturer's information:
 - 2.6.1 Material requested herein or in specifications. Term "Shop Drawings" refers to an outline, general arrangements, and installation requirement drawings needed to ensure that equipment to be supplied is in accordance with the Contract Specifications. Term "Shop Drawings" does not include drawings prepared solely for the manufacturer's use in fabrication of equipment.



- 2.6.2 Initial Submittal:
- 2.6.2.1 Drawings not larger than 36" x 120": Submit three (3) copies of each drawing to Procuring Entity. Copies of each drawings submitted by Contractor may be produced by any reproduction process except that producing blue-prints having white lines on a blue background.
 - 2.6.2.2 Drawings larger than 36" x 120", printed catalogue information or brochures or other multiple page documents: Submit three (3) copies of each drawing to Procuring Entity.
 - 2.6.2.3 The Contractor shall submit to the Procuring Entity, shop drawing for each item in the contract, which requires drawing approval, within thirty (30) calendar days after the date of contract ratification.
- 2.6.3 Procuring Entity will review shop drawings, indicate action taken, and return one (1) copy to Contractor. The Procuring Entity within thirty (30) calendar days after receiving such drawings, shall signify his approval or otherwise.
- 2.6.4 Additional copies and transmittal:
- 2.6.4.1 If Contractor's copy is marked "RESUBMIT", Contractor shall, within 15 days of receipt thereof, recheck drawing and make necessary revisions in accordance with comments noted on shop drawing and/or in separate letter and resubmit three (3) copies to the Procuring Entity for review. The Procuring Entity has 15 days to notify Contractor of his action or it will be deemed that the Procuring Entity has approved the resubmitted drawings.
 - 2.6.4.2 If Contractor's copy is marked "REVIEWED" OR "SUPPLEMENTAL REFERENCE", Contractor shall submit three (3) copies to the Procuring Entity for review. The Procuring Entity has 15 days to notify Contractor of his action or it will be deemed that the Procuring Entity has approved the resubmitted drawing.
- 2.6.5 Contractor's responsibility: Check shop drawings prior to submittal for errors, correctness of details and conformance with the Contract and for work detailed on the drawing.
- 2.6.6 Review of shop drawings by Procuring Entity does not relieve the Contractor of responsibility for errors, correctness of details or conformance with the Contract.



ITB NO. NE II-A1-2023-07

- 2.6.7 Contractor shall be responsible for making corrections to materials and equipment as required to obtain conformance with Contract requirements, whether such corrections are required during review of shop drawings, subsequent to release of drawings, data and information mentioned hereinafter, or after fabrication and shipment of materials and equipment.
- 2.6.8 Submit other information and/or samples as may be requested by the Procuring Entity within a reasonable time period.

3. CODES AND STANDARDS

- 3.1 Perform work in accordance with best present-day manufacturing practices.
- 3.2 Conform with and test in accordance with applicable sections of latest revisions of codes and standards listed in specifications.
- 3.3 Conflicts:
 - 3.3.1 Between referenced codes and standards: Codes and standards establishing more stringent requirement shall be followed.
 - 3.3.2 Between referenced codes and standards and specifications: One establishing more stringent requirements shall be followed.
- 3.4 For convenience in designation in the specifications, certain equipment, articles, materials or processes are designated by trade names of the manufacturer and/or catalogue names and numbers. Such designation shall be deemed to be followed by the words "equal or better" whether such words are shown or not. The Bidder may also offer alternative equipment, articles materials or processes provided that the alternative shall be equivalent or better in quality, suitability and convenience of use to that indicated or specified in the Contract Documents. Equipment articles, materials or processes meeting other standards which ensure an equal or higher quality than the standards mentioned will also be accepted at the discretion of the Procuring Entity. If the equipment, etc., are manufactured to standards other than shown in the bid documents, the bidder shall provide English Translation, by an accredited translation Agency, of the standard proposed in his bid at the time of submission of his bid proposal. It will be the bidder's responsibility to demonstrate and prove to the Procuring Entity's satisfaction that alternatives offered are substantially equivalent to the brand name identified.

The Bidder shall, in his bid, provide the name of the manufacturer and the catalogue number for each item of material listed on the Material Schedule plus the major items in the substations, and shall also provide the guaranteed losses for each transformer size and type.



ITB NO. NE II-A1-2023-07

- 3.5 Sources of Standards referred to this Bid shall conform with all pertinent laws, codes, and guidelines prescribed by the Philippine laws, such as but not limited to national building code, Philippine electrical code, provision set forth by the DPWH in building construction among others.

4. SPECIAL TOOLS

- 4.1 Provide any special tools, fixtures and instruments to EC which are necessary in construction, assembly, operation and maintenance of equipment.
- 4.2 Special tools and devices are those designed for purpose and use of which are peculiar to the equipment furnished and which are not available from normal wholesale or retail outlets. Standard general purpose tools are not included in this requirement.
- 4.3 Provide neat and substantial metal tool box with hinged cover and lifting handles or metal cabinet with hinged door, prominently marked box or cabinet "TOOLS FOR _____" for each set of tools furnished.

5. STRUCTURAL TESTS

- 5.1 Structural tests are specified and required by referenced codes and standards.
- 5.2 The Contractor shall provide Procuring Entity with certified copies of all test data and reports.
- 5.3 The Contractor shall withhold shipment until the Procuring Entity has examined and acknowledged the receipt of shop test data.

6. FACTORY TEST, INSPECTION AND TRAINING

- 6.1 **A minimum of two (2) Procuring Entity representative, at the expense of Contractor, shall have the right to inspect and/or test any material, equipment or supplies including attendance to appropriate training needs for logistics at the manufacturer site** (hereinafter collectively referred to in this clause as "Goods") furnished by the Contractor under this contract during manufacture and assembly and prior to packing for shipment and may reject any merchandise defective or unsuitable for the use and purpose intended, or not in accordance with the intent of the contract (see Section IV, Clause 5 for Sampling). The Contractor, upon demand by the Procuring Entity, shall remedy or replace at



his expense such defective or unsuitable Goods.

- 6.2 The Contractor shall notify in writing the Procuring Entity at least sixty days (60) days in advance of the date Goods will be ready for inspection in the shop or warehouse. The Procuring Entity's inspector shall, at all times during normal working hours, have access to all parts of the shop where Goods are being prepared and also shall be provided by the Contractor with all reasonable inspection and test facilities.
- 6.3 The fact that such factory inspection and/or test is made by the Procuring Entity, or fails to be made, shall not relieve the Contractor from full responsibility of the contract nor prejudice any claim, right, or privilege which the Procuring Entity may have because of the use of defective or unsatisfactory Goods.
- 6.4 The Procuring Entity shall be furnished written notice by the Contractor at least sixty (60) days in advance of the date that any test specifically identified in the Contract will be conducted. Failure on the Part of the Procuring Entity to witness any such test at the time and place indicated shall not delay the test or the orderly fulfilment of the provisions of the contract. Costs of all tests shall be on the account of the Contractor and included in the contract price.
- 6.5 The fact that the Procuring Entity shall have witnessed, or have failed to witness, such tests or any other test required by the conditions of the contract shall not constitute a waiver or release by the Procuring Entity of warranties under the contract. In the event that the Procuring Entity fails to witness test specified in the Contract after proper notice by the Contractor, the Contractor may deem such test as having been witnessed and proceed with the test, manufacture or shipment accordingly.
- 6.6 The manufacture and inspection of the material, equipment, or supplies are properly prepared for export shipment and the Contractor shall have furnished to the Procuring Entity an SGS pre-shipment Clean Report of Findings and a Certificate of Completion and Inspection to be included as Attachment.
- 6.7 Upon delivery, the Procuring Entity at its option may test the equipment for conformity to the specifications. If the Procuring Entity elects to perform tests and find the supplied equipment not in accordance with the specifications and/or with the test results provided by the Contractor, the equipment will be rejected.

7. DEFECTIVE EQUIPMENT AND MATERIALS

7.1 Defective equipment:

- 7.1.1 If equipment fails to conform to requirements of contract documents or to operate satisfactorily, the Contractor shall correct such defects



promptly at no cost to the Procuring Entity.

7.1.2 Procuring Entity will have right to operate unsatisfactory equipment until it is replaced or corrected without cost to depreciation, use or wear.

7.1.3 Equipment will be removed from operation for examination, adjustment, alteration or change at times approved by Procuring Entity.

7.2 Defective material:

7.2.1 If the Procuring Entity deems material to be defective through standard conformance test or from reported failures in actual use, the Procuring Entity shall reject the material and equipment and request the Contractor to replace the same. The Contractor, upon receipt of such notification shall replace the defective materials promptly at no cost to the Procuring Entity. If the Contractor fails to comply to the satisfaction of the Procuring Entity, the Procuring Entity may at its option:

7.2.1.1 Replace such defective material and recover the extra cost so involved from the Contractor; or

7.2.1.2 Terminate the contract for default as provided herein.

7.2.2 Contractor shall replace defective materials only at times approved by Procuring Entity.

8. EXPORT PACKING

8.1 When applicable, the Contractor shall pack and crate all equipment for sea shipment in a manner suitable for export to a tropical humid climate in accordance with internationally accepted export practices and in such a manner to protect the equipment from damage and deterioration in transit by road, rail or sea. The Contractor shall be held responsible for all damages due to improper packing.

8.2 Lumber used in the fabrication of all shipping containers shall be new, sound and well seasoned and free from knots and decay. Containers shall be sufficiently strong to prevent loss from pilferage or damage from stacking, shipment or handling.



ITB NO. NE II-A1-2023-07

- 8.3 Commodities subject to damage from the elements shall be preserved in a manner appropriate to the commodity and to the best commercial standards. Such commodities shall be packed in weatherproof crates or boxes with a waterproof liner.
- 8.4 Individual cartons or boxes shall be limited to approximately 50 kg to facilitate handling, unless individual items exceed this weight or unless stated otherwise in technical specifications. Commodities normally packed in cardboard containers shall be enclosed in weatherproof shipping crates or boxes with waterproof liners. All crates shall be skid mounted (100 mm minimum height) to allow handling by fork-lifts.
- 8.5 Because of fork-lift capacity, crates and pallets shall be limited to approximately 1,000 kg except where the unit weight of an item is in excess of 1,000 kg.
- 8.6 All material items shall be packed as specified or in manufacturers standard package quantities approved by the Procuring Entity if different than that specified. All packages (cartons) shall be packed as they would be when delivered to a retail Contractor and packages (cartons) of an item shall contain the same number of pieces. Bulk shipment is specifically prohibited. Individual packages (cartons) shall be sufficiently strong to withstand normal warehousing handling and storage.
- 8.7 Refer to Section IV, Clause 6, for additional requirements.

9. EXPORT MARKING

- 9.1 All packages, cartons, cases, and crates shall be plainly marked to facilitate identification as follows:

Port of Shipment	_____
Port of Destination	_____
Consignor	_____
Consignee	_____
Contract No.	_____
Gross Weight	_____
Package/Case No.	_____
Name of Coop	_____
Quantity	_____
Contents	_____
Item No.	_____

- 9.2 All external marking must be legibly and durably painted or stencilled on two



ITB NO. NE II-A1-2023-07

sides and both ends (where applicable) of containers in letters at least one and one-half inches (1-1/2") high.

- 9.3 All crates from one Contractor, regardless of port of shipment, shall be consecutively numbered to facilitate identification and delivery verification with shipping documents.
- 9.4 Reels shall bear markings on an embossed metal tag on both sides of the reel. Coils shall have markings on metal tags, one tied over the water proof paper wrapping and one tag under the paper wrap. Reels and spools shall be externally marked legibly and indelibly (chalk or crayon prohibited) with the information specified. Internally, conductor and cable ends shall have weatherproof tags attached containing full conductor or cable description plus length. Length given should be in metric units.
- 9.5 Conductor and cable shall be furnished on export type non-returnable wood reels of standard dimensions as defined for overhead electrical conductors by the American Aluminum Association, or IEC Standard, or equivalent. Reels shall incorporate full one-inch thick lagging and be bound with galvanized steel straps. The reels shall be sufficiently sturdy to withstand normal service incident to ocean shipping, hauling and field installation.

All wood used in reels and spools shall be treated with an approved wood preservative.

The conductor or cable shall be tightly laid on reel and layer wound and both ends must be clamped to the reel flange. The use of paper liners is prohibited but liners of other materials such as expanded polystyrene or similar plastic is required.

For random lengths a maximum of ten (10%) percent of the total weight of the conductor of any order may be shipped in random lengths but no piece may be shorter than fifty (50%) percent of a standard length. No random lengths shall be wound on the same reel with a standard length.

- 9.6 In the individual material specification and Schedule of Requirements, additional marking requirements may be specified. Recipient ECs shall be indicated in the markings by codes.
- 9.7 For failure to comply with the marking requirements as identified in this IFB, payment to the Contractor shall be reduced by the following:
- (a) 2% for failure to serially numbered all packages.



ITB NO. NE II-A1-2023-07

- (b) 3% for failure to provide correct listing of consignee and recipient coop for each serially numbered crate, box or package.
- (c) 5 % for marking package with wrong consignee or recipient coop.

NOTE: All percentages refer to the Contract price CIF of the Goods involved.

10. SAG AND TENSION TABLES

Contractors of overhead conductor and aerial cable shall furnish, at their expense, reproducible sag and tension tables for both initial (stringing) and final (after stretch and creep) conditions. Sag and tension tables shall be based on achieving maximum tension without exceeding the limit set forth by the following criteria.

- (1) Maximum Loaded Tension not to exceed fifty (50%) percent of ultimate tensile strength at -1 degree C, loaded under 44 kg/m^2 (9lb./ft²) wind pressure.
- (2) Maximum Unloaded Initial Tension at -1 degree C not to exceed thirty five (35%) percent of ultimate tensile strength.
- (3) Maximum Unloaded Final Tension at -1 degree C not to exceed twenty five (25%) percent of ultimate tensile strength.

Temperature Range of Tables:

For temperature range from -1 degree C to 50 degree C in increments of 2 degree C.

Span Length Range of Tables - Bare Conductor:

For Dead-end Spans of lengths ranging from 50 m through 600 m:

- in 10-meter increments for spans from 50 meters through 200 meter;
- in 25-meter increments for spans from 200 meters through 600 meters.

Span Length Range of Tables - Low Voltage and Power Cables:

For Dead end Spans of lengths ranging from 20 meters through 150 meters: in 5-meter increments.



11. QUALIFIED MANUFACTURERS

- 11.1 A foreign or domestic manufacturer shall prove its qualification by attesting that he sold material, equipment or supplies of similar nature to that being proposed for at least the period of years and the quantities as required on the Certification Requirements for Material and Equipment. A foreign manufacturer shall prove additionally that he sold material, equipment or supplies of similar nature to that being proposed in foreign transactions in each of the last three years and in all of which the buyer still express satisfaction with the performance of the goods.
- 11.2 The manufacturing experience requirement can be met as follows:
- a. The manufacturer has the required years of manufacturing the item and the required sales, or
 - b. The manufacturer is a licensed manufacturer with the licensor controlling the design and quality of the output, and the licensor meets the experience and sales requirements.
- 11.3 The bidder shall include in his bid, and attach to his bid response, certification that the manufacturer of the proposed material or equipment has manufactured material and equipment the same as or similar to the material being offered over the periods designated below for items contained in the respectively noted Material Specification. The bidder shall also include for each certification a list of at least three (3) previous Procuring Entity outside the country of the manufacturer along with a description and the quantities of supplied material or equipment, same as or similar to that being offered, giving full names, addresses, phone and fax numbers of these Procuring Entities.

12. STANDARDS AND SPECIFICATIONS

Notes on Specifications

A set of precise and clear specifications is a prerequisite for Bidders to respond realistically and competitively to the requirements of the Procuring Entity without qualifying or conditioning their Bids. In the context of international competitive bidding, the specifications must be drafted to permit the widest possible competition and, at the same time, present a clear statement of the required standards of workmanship, materials, and performance of the goods and services to be procured. Only if this is done will the objectives of economy, efficiency, and fairness in procurement be realized, responsiveness of Bids be ensured, and the subsequent task of bid evaluation facilitated. The specifications should require that all goods and materials to be incorporated in the Works be new, unused, of the most recent or current models, and incorporate all recent improvements in design and



materials unless provided otherwise in the Contract.

Samples of specifications from previous similar projects are useful in this respect. The use of metric units is mandatory. Most specifications are normally written specially by the Procuring Entity or its representative to suit the Works at hand. There is no standard set of Specifications for universal application in all sectors in all regions, but there are established principles and practices, which are reflected in this bidding document

There are considerable advantages in standardizing General Specifications for repetitive Works in recognized public sectors, such as highways, ports, railways, urban housing, irrigation, and water supply, in the same country or region where similar conditions prevail. The General Specifications should cover all classes of workmanship, materials, and equipment commonly involved in construction, although not necessarily to be used in a particular Works Contract. Deletions or addenda should then adapt the General Specifications to the particular Works.

Care must be taken in drafting specifications to ensure that they are not restrictive. In the specification of standards for goods, materials, and workmanship, recognized international standards should be used as much as possible. Where other particular standards are used, whether national standards or other standards, the specifications should state that goods, materials, and workmanship that meet other authoritative standards, and which ensure substantially equal or higher quality than the standards mentioned, will also be acceptable.

Sample Clause: Equivalency of Standards and Codes

Wherever reference is made in the Contract to specific standards and codes to be met by the goods and materials to be furnished, and work performed or tested, the provisions of the latest current edition or revision of the relevant standards and codes in effect shall apply, unless otherwise expressly stated in the Contract. Where such standards and codes are national, or relate to a particular country or region, other authoritative standards that ensure a substantially equal or higher quality than the standards and codes specified will be accepted subject to the Procuring Entity's Representative's prior review and written consent. Differences between the standards specified and the proposed alternative standards shall be fully described in writing by the Contractor and submitted to the Procuring Entity's Representative at least twenty-eight (28) days prior to the date when the Contractor desires the Procuring Entity's Representative's consent. In the event the Procuring Entity's Representative determines that such proposed deviations do not ensure substantially equal or higher quality, the Contractor shall comply with the standards.



13. MATERIAL SPECIFICATIONS LISTING

Each item of material is described in a Material Specification which has a descriptive title and an assigned reference number. This reference number is cross referenced on the Bill of Quantities, which is a listing of each item of material, with quantities, that is to be provided by the Contractor.

The Material Specifications describe the detailed technical requirements of materials, supplies, and equipment to be furnished under this proposal.

The bidder must quote prices on the Material Schedule which include the cost of all accessory or auxiliary parts (mounting brackets, terminal connectors, spare parts, gauges, etc.) that are specified in the Material Specifications to be furnished with the item, even though such accessory or auxiliary parts may not be specially mentioned in the brief item description contained on the Material Schedule.



SECTION VI. FORMS

TABLE OF FORMS

FORM NUMBER	TOPIC	PAGE NUMBER
1	Bid	VI - 1
2	Bid Security	VI - 2
3	Power of Attorney	VI - 3
4	Letter of Authorization	VI - 4
5	Contract	VI - 6
6	Acknowledgement	VI - 9
7	Performance Security	VI - 9
8	Deviation Form	VI - 10
9	Acknowledgement Receipt	VI - 10



FORM 1: BID

Date: _____
 Location: _____
 Contract _____
 No: _____

TO: Bid and Awards Committee
 Nueva Ecija II Electric Cooperative, Inc.- Area-1
 Calipahan, Talavera
 3114 Nueva Ecija

Gentlemen:

Having examined the Bidding Documents including Addenda Nos. (Insert Numbers), the receipt of which is hereby duly acknowledged, we, the undersigned, offer to deliver (Description of materials) in conformity with the said Bid Documents for the sum of (Total Bid Amount in Words and Figures) or such other sums as may be ascertained in accordance with the Price Schedules attached herewith and made part of this bid.

We undertake, if our bid is accepted, to commence the delivery within (Number) days to complete the project of all the items specified in the Contract within the (Number) days to be calculated from the date of receipt of your Purchase Order.

If our bid is accepted we will post performance security in form of Manager's Check in a sum not exceeding five percent (5%) of the Bid Price for the due performance of the Contract.

We agree to abide by this bid for a period of (Number) days from the date fixed for bid opening and it shall remain binding upon us and may be accepted at any time before the expiration of that period.

Until a formal contract is prepared and executed, this bid, together with your written acceptance thereof and your Notice of Award/Purchase Order, shall constitute a binding Contract between us.

We understand that you are not bound to accept the lowest or any bid you may receive.

Dated this day of , 2023.

 Signature

 (In capacity of)

Duly authorized to sign bid for and on behalf of _____.



FORM 2: BID SECURITY

WHEREAS, hereinafter called "the BIDDER" has submitted its bid dated for the construction of _____ (hereinafter called "the BID").

KNOW ALL MEN BY THESE PRESENTS:

That, WE, of , having our registered office at (hereinafter called "the BANK") are the bound unto (hereinafter called "the COOPERATIVE") in the sum of for which payment will truly to be made to the said COOPERATIVE, the Bank binds itself, its successors and assigns by these presents.

Sealed with the common seal of the said Bank this day of , 2023.

THE CONDITIONS of this obligation are:

- 1) If the Bidder withdraws its Bid during the period of bid validity specified by the Bidder on the Bid Form; or
- 2) If the bidder, having been notified of the acceptance of its bid by the Cooperative during the period of validity:
 - a. fails or refuses to execute the Contract Form, if required; or
 - b. fails to refuses to furnish the Performance Security, in accordance with the Instructions to Bidders;

We undertake to pay to the Cooperative up to the above amount upon receipt of its first written demand, without the Cooperative having to substantiate it demand, provided that in this demand the Cooperative will note that the amount claimed by it is due to it owing to the occurrence of one or both of the two conditions, specifying the occurred condition or conditions.

This guarantee will remain in force up to and including thirty (30) days after the period of bid validity, and any demand in respect thereof should reach the Bank not later than the above date.

(Signature)



FORM 3: POWER OF ATTORNEY

KNOW ALL MEN BY THESE PRESENTS:

That we, _____, a company organized and existing under the laws of _____, having the principal office at _____ do hereby make, constitute, and appoint _____ our true and lawful attorneys-in-fact to act for us, on our behalf, and in name, by investing them with the following powers:

- 1) To make any proposal to and/or negotiate and execute the contract or any other agreement with (NEECO II Area-1), its representative and/or agents, if any, relating to the bid of the Construction of MCO Multi-Purpose Building.
- 2) To receive, accept and acknowledge any notice issued under the contract, any other agreement and/or any other proposal.
- 3) To do any and all acts and things and execute any and all instruments, certificates and agreement which they may deem necessary or advisable, or which may be required for or in connection with the execution of the said contract.

IN WITNESS WHEREOF, we have cause this POWER OF ATTORNEY to be executed in our name by our _____ thereunto duly authorized, in _____ this day of _____, 20_____.

(CORPORATION)

by: PRINTED NAME
POSITION/TITLE



FORM 4a: LETTER OF AUTHORIZATION FROM THE MANUFACTURER TO THE BIDDER

Construction of MCO Multi-Purpose Building

To whom it may concern:

We, _____, a juridical person, organized and existing under the laws of _____ having its principal business office at _____ hereby authorizes _____ having its registered office at _____ to offer and supply our goods to the _____ Electric Coop., Inc.

This Letter of Authorization is effective from this _____ day of _____ 20__ and remains in full force until the completion of the contract.

(CORPORATION)

by: _____
PRINTED NAME

POSITION / TITLE



FORM 4b: LETTER OF AUTHORIZATION FROM THE BIDDER THE LOCAL AGENT

Construction of MCO Multi-Purpose Building

To whom it may concern:

We, _____ (company) _____, a juridical person, organized and existing under the laws of _____ (country) _____ having its principal business office at _____ (address) _____ hereby appoint _____ (company) _____ having its registered office at _____ (address) _____ as our local agent/representative. In particular, our local agent/representative is authorized to _____.

This Letter of Authorization is effective from this _____ day of _____ 20__ and remains in full force until the completion of the contract.

(CORPORATION)

by: _____
PRINTED NAME

POSITION/TITLE



FORM 5: CONTRACT

CONTRACT FOR THE
Construction of MCO Multi-Purpose Building

INVITATION FOR BIDS NO. NE-II-A1-_____ - _____

KNOW FOR ALL MEN BY THESE PRESENTS

This Contract entered into this ___th day of _____, 2023 at Nueva Ecija II Electric Cooperative, Inc. (NEECO II-Area 1) Main Office, Brgy. Calipahan, Talavera, Nueva Ecija by and between:

The Nueva Ecija II Electric Cooperative, Inc. – Area I (NEECO II – AREA 1), a duly organized electric cooperative and existing under and by virtue of the laws of the Philippines, with principal office at Brgy. Calipahan, Talavera, Nueva Ecija, herein represented in this contract by _____ and hereinafter referred as the “COOPERATIVE”.

-and-

WITNESSETH

1. That, the COOPERATIVE, with Board Resolution No. 09-04-23, Series of 2023 conducted public bidding for **Construction of MCO Multi-Purpose Building** Invitation to Bid (ITB) No. NE-II-A1-2023-07 which was published in Philippine Star on September 17, 2023.
2. That, the BAC, after careful review and evaluation on the bid offers, has awarded the Construction of MCO Multi-Purpose Building with corresponding contract price of _____;
3. That, as per recommendation of the BAC which was duly approved by the Board of Directors under Board Resolution No. _____ dated _____, the COOPERATIVE awards the contract to _____ with corresponding amount of _____;

NOWHEREFORE, for and in consideration of the foregoing premises the parties hereto agree and contract as follows:

- 1) A copy of bid documents and the Invitation for Bid No. NE-II-A1-2023-07, authority of signing official, electrification schedule, project organizational chart, manpower schedule, equipment utilization schedule of all equipment and machineries which shall be used exclusively for the project, bid summary/ Contractor's bid price offered, detailed estimation of materials, notice of award, notice



- to proceed, performance security, and other documents establishing the eligibility of the Contractor, are hereto attached and made an integral part of this contract;
- 2) The CONTRACTOR agrees and binds itself to fully and faithfully provide for its accounts all provisions necessary in the completion of the **Construction of MCO Multi-Purpose Building**
 - 3) within ___ **Calendar Days** including the testing and commissioning, commencing on the date of issuance of Notice to Proceed and the turn-over of the project;
 - 3) The CONTRACTOR shall post a **Performance Security Bond in the amount of _____, equivalent to 10% of the Contractor's Bid Price** which is to be returned to the Contractor after testing and commissioning of the project and not later than thirty (30) days following the date of the issuance of the Certificate of Completion of the Contractor's Performance under the Contract
 - 4) In the event of a delay in work caused by fortuitous events or force majeure, the CONTRACTOR may request for an extension of time, in writing, within three (3) days following the occurrence of the cause of delay. The grant of extension, which shall also be in writing, may not be unreasonably withheld. It shall be understood that the approval of the request for extension of time shall not be construed as to automatically entitle the CONTRACTOR to a cost adjustment;
 - 5) The CONTRACTOR shall exert its best efforts to execute its obligations under the contract in accordance to all the documents made to form part of this contract;
 - 6) The contract price shall be broken down as shown in the bid form of the CONTRACTOR. The required down payment, if any, shall be made upon the written request of the Contractor, and after the Contractor's mobilization of materials. The balance shall be by progress payments based on the estimated amount of work satisfactorily completed by the CONTRACTOR and accepted by the COOPERATIVE for every progress billing in accordance with the General Conditions of the Contract;
 - 7) Time is an essential feature of this contract in the event that the CONTRACTOR fails to complete the _____ within the stipulated time inclusive of any granted extension of time, the CONTRACTOR shall pay the COOPERATIVE, as liquidated damages for its calendar day of delay, an amount equivalent to be computed in accordance with the General Conditions of the Contract;
 - 8) The CONTRACTOR shall guarantee the quality of all materials it will supply, deliver and use in the _____ and shall make good all defect/s attributable to the quality of materials and workmanship which may be discovered within one (1) year reckoned from the date of issuance of certificate of completion;
 - 9) Equipment/Materials which are the subject matter of this Contract, or are in any way used in the performance or execution of this contract may be inspected and tested at all reasonable times and places, either before, during or after manufacture by the COOPERATIVE at its discretion. If inspection and tests are made on the premises of CONTRACTOR or CONTRACTOR's sub-contractor, the CONTRACTOR shall furnish without additional charge all reasonable facilities and assistance for the safe and convenient inspection and test required by at least a minimum of two (2) Cooperative representatives in the performance of their duty. No shipments shall be made without prior inspection or waiver of inspection issued by the Cooperative;
 - 10) The COOPERATIVE or its authorized representative shall be entitled at all reasonable times to witness and conduct standard association tests, standard factory inspection and/or other tests



specifies herein. The CONTRACTOR shall provide reasonable copies of witnessed test result to COOPERATIVE, if required:

- 11) The Cooperative shall, upon the written request of the Contractor, and after the Contractor's mobilization of materials, may be allowed to make a **DOWN PAYMENT** equivalent to **15% of the contract price**. The balance from the Contract Price shall be paid by the Coop thru progress billings based on the estimated work satisfactorily completed by the Contractor and accepted by the Cooperative for every progress billing;
- 12) In the event that the Contractor fails to complete the infrastructure projects within the stipulated time inclusive of the granted extension of time, if any, the Contractor shall pay the Cooperative, as **Liquidated Damages** for its calendar day of delay, an amount equal to 1/10 of 1% (.01%) of the cost of the unperformed portion of the contract, for every day of delay. Once the cumulative amount of liquidated damages reaches ten percent (10%) of the amount of the contract, the contract shall be rescinded without prejudice to other courses of action and remedies to be undertaken.
- 13) Progress payments/ billings are subject to ten percent (10%) **retention** of the billings to answer for any uncorrected/discovered defects and third party liabilities and may be released within sixty (60) days after the issuance of Certificate of Final Inspection and Acceptance and all the discovered defects in the project has been corrected and in exchange thereof, shall post a **Guarantee Bond equivalent to five percent (5%) of the Contract Price**;
- 14) The Contractor shall issue a Guarantee Bond in the form of Manager's Check in conformity with the general conditions of the contract, equivalent to Five Percent (5%) of the contract price to serve as warranty against defective works and materials for a period of two (2) years reckoned from the date of Final Inspection and Acceptance. The Guarantee Bond shall be released at the end of the guarantee period provided there are no pending reservations for its release. Thereafter, the Contractor is relieved of all obligations under the Contract;
- 15) The CONTRACTOR obligates to comply with the provisions of the existing laws, executive and administrative orders and rules and regulations issued or to be issued pertinent to the CONSTRUCTION OF THE PROJECTS;
- 16) The COOPERATIVE shall have the rights to automatically terminate the contract in the event that the CONTRACTOR incurs unjustified delays;
- 17) In case of litigation arising out of this contract, the parties hereto agree that its venue shall be in the proper court in Nueva Ecija, under the laws of the Philippines.

IN WITNESS WHEREOF, the parties have hereunto signed this contract on the date and place first above written.

**NUEVA ECIJA II ELECTRIC COOPERATIVE,
INC.- Area 1 (NEECO II-AREA 1)**

By:

By:

ENGR. NELSON M. DELA CRUZ
General Manager



ACKNOWLEDGEMENT

REPUBLIC OF THE PHILIPPINES }
 Municipality of Talavera } S.S.
 Province Of Nueva Ecija }

BEFORE ME, a Notary Public within and for _____, Philippines, this _____ day of _____, 2023, personally appeared ENGR. NELSON M. DELA CRUZ, and _____, exhibiting their valid identification cards, all known to me as the same persons who executed the foregoing instrument and each of them acknowledged to me that the same is their free act and deed as well as free act and deed of the Cooperative/Corporation which they respectively represent.

This Contract is consisting of five (5) pages including the page, on which this Acknowledgement is written, with each and every page duly signed by the parties and their instrumental witnesses.

WITNESS MY HAND AND SEAL on the date and place above written.

Notary Public

Doc. No.; _____
 Page No.; _____
 Book No.; _____
 Series of 2018

FORM 7: PERFORMANCE SECURITY

TO: (Name of COOPERATIVE)

WHEREAS, _____ (Name of Contractor) hereinafter called "the CONTRACTOR" has undertaken, in pursuance of Contract No. dated _____, 20__ to construct (Description of Project) hereinafter called "the CONTRACT";

AND WHEREAS it has been stipulated by you in the said contract that the CONTRACTOR shall furnish you with a Bank Guarantee by recognized bank for the sum specified therein as a security for compliance with the CONTRACTOR's performance obligations in accordance with the Contract;

AND WHEREAS we have agreed to give the CONTRACTOR a Guarantee;



THEREFORE WE hereby affirm that we are Guarantors and responsible to you, on behalf of the CONTRACTOR, up to a total of (Amount of the Guarantee in words and figures) and we undertake to pay you, upon your first written demand declaring the CONTRACTOR to be in default under the Contract and without cavil or argument, any sum of sums within the limits of (Amount of Guarantee) as aforesaid, without your needing to prove or to show grounds or reasons for your demand or the sum specified therein.

This guarantee is valid until the day of , 2023.

Signature and seal of the Guarantors

FORM 8: DEVIATIONS

Reference to the Specifications	Requirements of Specifications	Detailed Description of the Deviations from the Specifications

FORM 9: ACKNOWLEDGEMENT RECEIPT

BACKGROUND

As the results of the innovative of NEECO II-Area 1's procurement process and policy, the Bids and Awards Committee (BAC), releases copies of bidding documents in soft copy through electronic data.

BIDDER'S INFORMATION

(Bidder/Company Name), an entity duly organized and existing under and by virtue of the laws of the Republic of the Philippines, with office address at (Bidder/Company Address), represented by its (Name of Bidder's Representative and designation) hereinafter referred to as the "BIDDER"



ACCEPTANCE OF BIDDING DOCUMENTS

That we, (Bidder/Company Name) hereby confirm the receipt of the copy of bidding documents for the Construction of MCO Multi-Purpose Building soft copy form.

Whereby, in cases of any inconsistency or discrepancy on the contents of bidding documents between the copy of the Bidders and the original copy secured from NEECO II-Area 1, the contents of the original copy shall prevail.

CONFORME:

(Printed Name & Signature of Duly
Authorized Representative)

DATE: _____

Project: PROPOSED THREE STOREY BUILDING
 Location: TALAYERA, NUEVA ECUIA
 Owner: NEECO II - AREA I

BILL OF MATERIALS & COST ESTIMATES

I. Mobilization and Construction of TEMPACIL

Qty = 1.00 ls

Material Cost

QTY	UNIT	DESCRIPTION	UNIT COST	AMOUNT
12	pcs	1/4" thk. Ordinary Plywood		
240	bd.ft.	Assorted Coco Lumber		
12	pcs	Corr. GI Sheets 12ft		
4	pcs	Receptacle 2X3		
4	pcs	Switch		
4	pcs	Convenience Outlet		
50	pcs	4" CHB		
10	pcs	10 mm RSB		
15	bag	Cement		
3	cum	Sand		
10	kgs.	Assted CWN		
2	kgs.	GI Wire		
1	box	#12 cu. Wire		
2	pcs	Lighting Bulb		
1	pcs	Breaker		
1	pcs	Electrical Tape		

Labor Cost

QTY	DESCRIPTION	NO. OF DAYS	UNIT COST	AMOUNT
1	Foreman	2		
2	Skilled	2		
3	Laborer	2		

SUB-TOTAL=

II. Demolition Works

Labor Cost

QTY	DESCRIPTION	NO. OF DAYS	UNIT COST	AMOUNT
1	Foreman	7		
15	Laborer	7		

SUB-TOTAL=

III. Excavation Works

Qty = 812.00 cu.m.

Equipment Rental Cost

QTY	UNIT	DESCRIPTION	UNIT COST	AMOUNT
30	hr	Excavator		

Labor Cost

QTY	DESCRIPTION	NO. OF DAYS	UNIT COST	AMOUNT
1	Foreman	3		
2	Laborer	3		

SUB-TOTAL=

IV. Filling Works

Qty = 812.00 cu.m.

Material Cost

QTY	UNIT	DESCRIPTION	UNIT COST	AMOUNT
285	cu.m.	Filling Materials		
40	cu.m.	G1 Gravel (for Gravelbed)		

Equipment Rental Cost

QTY	UNIT	DESCRIPTION	UNIT COST	AMOUNT
40	hr	Bulldozer		

Labor Cost

QTY	DESCRIPTION	NO. OF DAYS	UNIT COST	AMOUNT
1	Foreman	3		
8	Laborer	3		

SUB-TOTAL=**V. Formwork & Scaffolding**

Qty. = 1.00 i.s.

Scaffolding Rental Cost

QTY	UNIT	DESCRIPTION	UNIT COST	AMOUNT
150	set	Scaffolding H-Frame		
500	pcs	1-1/2 Ø G.I. Pipe s-40		
500	set	Shoring Jack , Accessories		
120	pcs	Platform		

Material Cost

QTY	UNIT	DESCRIPTION	UNIT COST	AMOUNT
200	pcs	3/4" thick Phenolic Board		
1,200	bd.ft.	Assorted Good Lumber		
90	kgs.	Assorted CWN		

Labor Cost

QTY	DESCRIPTION	NO. OF DAYS	UNIT COST	AMOUNT
1	Foreman	8		
13	Skilled	8		
15	Laborer	8		

SUB-TOTAL=**VI. Reinforcing Steel Bar**

Qty = 41,376.00 kgs.

A. Material Cost

QTY	UNIT	DESCRIPTION	UNIT COST	AMOUNT
1,300	pcs	20mm x 6mts RSB		
900	pcs	16mm x 6mts RSB		
600	pcs	12mm x 6mts RSB		
3,000	pcs	10mm x 6mts RSB		
132	rolls	# 16 G.I Wire		

Labor Cost

QTY	DESCRIPTION	NO. OF DAYS	UNIT COST	AMOUNT
1	Foreman	60		
10	Skilled	60		
12	Laborer	60		

SUB-TOTAL=

VII. Decking

A. Material Cost

QTY	UNIT	DESCRIPTION	UNIT COST	AMOUNT
580	l.m.	SD 850 X1.2mm		
2,500	pcs	20mmØ x 75mm Shear Studs		
8	box	Welding Rod		

Labor Cost

QTY	DESCRIPTION	NO. OF DAYS	UNIT COST	AMOUNT
1	Foreman	10		
10	Skilled	10		
12	Laborer	10		

SUB-TOTAL=

VIII. Concrete Works

Qty = 310.00 cu.m.

A. Material Cost

QTY	UNIT	DESCRIPTION	UNIT COST	AMOUNT
310	cu.m.	ReadyMix 3500 psi 3/4 crushed		
2	unit	Pumcrete Rental		

Labor Cost

QTY	DESCRIPTION	NO. OF DAYS	UNIT COST	AMOUNT
1	Foreman	14		
12	Laborer	14		

SUB-TOTAL=

IX. Masonry Works and Plastering

Material Cost

QTY	UNIT	DESCRIPTION	UNIT COST	AMOUNT
800	bags	Portland Cement		
12,100	pcs	100mm thk CHB		
5,660	pcs	150mm thk CHB		
250	cu.m.	Screened Wash Sand		

Labor Cost

QTY	DESCRIPTION	NO. OF DAYS	UNIT COST	AMOUNT
1	Foreman	21		
12	Skilled	21		
15	Laborer	21		

SUB-TOTAL=

X. Ceiling Works

Qty. = 1.00 l.a.

Material Cost

QTY	UNIT	DESCRIPTION	UNIT COST	AMOUNT
1,180	pcs	Acoustic Ceiling Board 2ft x 2ft		
98	pcs	Main Tee		
140	pcs	Cross Tee		
112	pcs	Edge Moulding		
200	sets	Hanger Wire		
186	pcs	Wall Liner (B R)		
245	pcs	Hardieflex 1/4" thk		
245	pcs	Metal Furring (0.40mm thk)		

310	pcs	Carrying Channel (0.40mm thk)
200	pcs	Wall Angle (0.40mm thk)
400	sets	Suspension Clip & Rod Joiner
2,000	pcs	W-Clip
3,400	pcs	Hardi Drive Screw
70	kgs	Concrete Nail #1
12	pcs	Masonry Drill Bit 3mm Ø
30	pcs	Metal Drill Bit (5/32" Ø)
60	box	Blind Rivets

Labor Cost				
QTY	DESCRIPTION	NO. OF DAYS	UNIT COST	AMOUNT
1	Foreman	18		
15	Skilled	18		
10	Laborer	18		

SUB-TOTAL=

XI. Steel Truss/Roof Framing/Railings

Qty = 1.00 i.s.

Material Cost				
QTY	UNIT	DESCRIPTION	UNIT COST	AMOUNT
1	set	Stair/Ramp Railings		
74	pcs	2 x 6 x 150mm Tubular		
25	pcs	2 x 4 x 120mm Tubular		
140	pcs	2 x 4 x 120mm C-Purlins		
24	pcs	1 X1 X 150mm Tubular		
32	pcs	Flat Bar 4mm x 1" x 6m		
12	gal	Red Oxide		
23	gal	Paint Thinner		
8	pcs	Paint Brush 2"		
6	pcs	Paint Brush 4"		
5	pcs	Cutting Disk		
36	pcs	12mm Ø (Sag Rod)		
6	box	Welding Rod		

Labor Cost				
QTY	DESCRIPTION	NO. OF DAYS	UNIT COST	AMOUNT
1	Foreman	12		
8	Skilled	12		
10	Laborer	12		

SUB-TOTAL=

XII. Transmitting Works

Qty = 1.00 i.s.

Material Cost				
QTY	UNIT	DESCRIPTION	UNIT COST	AMOUNT
476	l.m.	Rib type Roofing		
12	rolls	Roof Insulation		
97	l.m.	Gutter		
97	l.m.	Fascia cover		
4	rolls	#18 GI Wire		
2,400	pcs	Teckacrew		
6	box	Blind Rivet		
3	ltr	Vulcaseal		

Labor Cost				
QTY	DESCRIPTION	NO. OF DAYS	UNIT COST	AMOUNT
8	Skilled	10		
7	Laborer	10		

SUB-TOTAL=

XIII. Doors and Windows

Qty = 1.00 Ls.

Materials				
QTY	UNIT	DESCRIPTION	UNIT COST	AMOUNT
10	sets	3.20 x 2.10 Fixed/Casement Window		
3	sets	1.90 x 2.10 Fixed/Casement Window		
9	sets	0.70 x 0.50 Awning Window		
4	sets	0.80x 1.27 Casement Window		
2	sets	3.00 x 2.10 Fixed/Sliding Window		
1	sets	5.40 X 3.00 Fixed Window		
1	sets	2.10 x 6.00 Tempered Glass Door		
7	sets	2.10 x 1.00 Frameless Glass Door		
8	sets	2.10 x 0.80 Panel Door		
2	sets	2.10 x 1.50 Upholstered Panel Door		
3	sets	Fire Exit Door		
2	sets	2.10 x 0.90 Panel Door		

Labor Cost			
DESCRIPTION	UNIT COST	AMOUNT	
Installation Fee	10% of Material Cost		

SUB-TOTAL=

XIV. Tile Works

Material Cost

QTY	UNIT	DESCRIPTION	UNIT COST	AMOUNT
1,900	pcs	60 x 60 Glazed Ceramic Tiles		
1,120	pcs	50 x 50 Carpet Tiles		
5	slabs	Salt and Pepper Granite		
180	bag	Cement		
50	cu-m	Sand		
400	bag	Tile Adhesive		
50	cls	Tile Grout		

Labor Cost				
QTY	DESCRIPTION	NO. OF DAYS	UNIT COST	AMOUNT
1	Foreman	21		
13	Skilled	21		
15	Laborer	21		

SUB-TOTAL=

XV. Plumbing Works

Qty = 1.00 Ls.

Materials				
Qty	UNIT	DESCRIPTION	UNIT COST	AMOUNT
A. Water Line				
42	pcs	1/2" Ø PP-R Pipe		
16	pcs	1/2" Ø PP-R Coupling		
31	pcs	1/2" Ø PP-R Tee		
15	pcs	1/2" Ø PP-R Elbow		
15	pcs	1/2" Ø PP-R Elbow Adaptor		
B. Waste Line				
56	pcs	4"Ø PVC Pipe S-1000		

18	pcs	2"Ø PVC Pipe S-1000
3	lit	Solvent Cement
8	pcs	4 x 2 Wye
15	pcs	4 x 4 Tee
4	pcs	4"Ø 45 deg Elbow
41	pcs	2"Ø P-trap
23	pcs	2"Ø 45 deg Elbow
8	pcs	2"Ø Elbow
2	pcs	4"Ø Clean out

C. Plumbing Fixtures

17	sets	Water Closet
5	sets	Urinal
17	sets	Lavatory
1	sets	Sink
17	sets	Sprinkler Bidet
4	sets	Shower
18	pcs	Floor Drain

Labor Cost

QTY	DESCRIPTION	NO. OF DAYS	UNIT COST	AMOUNT
1	Foreman	18		
8	Skilled	18		
10	Laborer	18		

SUB-TOTAL=

XVI. Painting Works

A. Material Cost

QTY	UNIT	DESCRIPTION	UNIT COST	AMOUNT
41	tins	Flat Latex Paint		
41	tins	Semi-Gloss		
60	gals	Conc. Neutralizer		
8	gals	Gypsum Putty		
12	gals	Well Putty		
40	gals	Paint Thinner		
410	sack	Skim Coat		
200	ft	Sand Paper # 120		
200	ft	Sand Paper # 100		
200	ft	Sand Paper # 80		
50	pcs	masking tape		
15	kis	newspaper		
50	roll	Gaza Tape		
10	kis	Rags		
8	tins	Gloss Latex		
10	pcs	Paint Roller w/ tray		
10	pcs	Paint Brush # 1		
10	pcs	Paint Brush # 2		

Labor Cost

QTY	DESCRIPTION	NO. OF DAYS	UNIT COST	AMOUNT
1	Foreman	15		
8	Skilled	15		
10	Laborer	15		

SUB-TOTAL=

XVII. Electrical Works

Qty = 1.00 l.s.

A. Material Cost

QTY	UNIT	DESCRIPTION	UNIT COST	AMOUNT
14	rolls	2.0 mm ² THW wire stranded		

16	rolls	3.5 mm ² THW wire stranded
8	rolls	5.5 mm ² THW wire stranded
16	mts	38 mm ² THW cu. Wire
44	pcs	LED Panel Light
81	pcs	Pin Lights
14	pcs	Center Lights
4	pcs	Wall Lamp
4	sets	1-gang switch w/ plate
5	sets	2 gang switch w/ plate
16	sets	3 gang switch w/ plate
83	sets	2-Gang Convenience Outlet w/ plate
8	sets	2-Gang Weather Proof CO
60	pcs	20mm Ø PVC Electrical Pipe
40	pcs	20mm Ø PVC Long Elbow
190	pcs	20mm Ø PVC Connector
4	lit	Solvent Cement
6	length	1 1/2" RSC Pipe
6	pcs	1 1/2" RSC elbow
8	pcs	1 1/2" RSC Lock Nut & Bushing
6	pcs	1 1/2" RSC Coupling
2	pcs	1 1/2" Entrance Cap
20	pcs	Electrical tape big
114	pcs	2 1/2" x 4" Utility Box
32	pcs	4" x 4" Junction Box
2	pcs	Panel Board 38 Holes/Branches
1	pcs	Panel Board 18 Holes/Branches
20	pcs	15 amp Circuit Breaker
12	pcs	20 amp Circuit Breaker
2	pcs	200 amp Circuit Breaker
1	pcs	300 amp Circuit Breaker

Labor Cost

QTY	DESCRIPTION	NO. OF DAYS	UNIT COST	AMOUNT
8	Skilled	15		
8	Laborer	15		

SUB-TOTAL=

XVIII. Cladding Works

Labor Cost

QTY	UNIT	DESCRIPTION	UNIT COST	AMOUNT
195	sqm	Aluminum Composite Panels 4mm thk		
72	pcs	Outdoor Fluted Wall Panels (Oak)		
38	pcs	Indoor Fluted Wall Panels (Cedar)		
110	sets	Accessories		

Labor Cost

QTY	UNIT	DESCRIPTION	UNIT COST	AMOUNT
110	panel	Installation Fee		

SUB-TOTAL=

XIX. Canopy

Material Cost

QTY	UNIT	DESCRIPTION	UNIT COST	AMOUNT
1	lot	Tempered Glass		
1	set	Accessories		
16	pcs	2 x 8 x 1.5 Tubular		

Labor Cost				
QTY	DESCRIPTION	NO. OF DAYS	UNIT COST	AMOUNT
5	Skilled	4		
3	Laborer	4		

SUB-TOTAL=

XX.Mechanical/Electronics

Material Cost				
QTY	UNIT	DESCRIPTION	UNIT COST	AMOUNT
1	lot	Elevator Hairline Stainless 400kg		
1	lot	Airconditioning System		
1	lot	Fire Protection System		
1	lot	Network System		
1	lot	Surveillance System		

SUB-TOTAL=

XXI. Clearing & Demobilization

Labor Cost				
QTY	DESCRIPTION	NO. OF DAYS	UNIT COST	AMOUNT
1	Foreman	5		
5	Laborer	5		

SUB-TOTAL=

TOTAL PROJECT COST

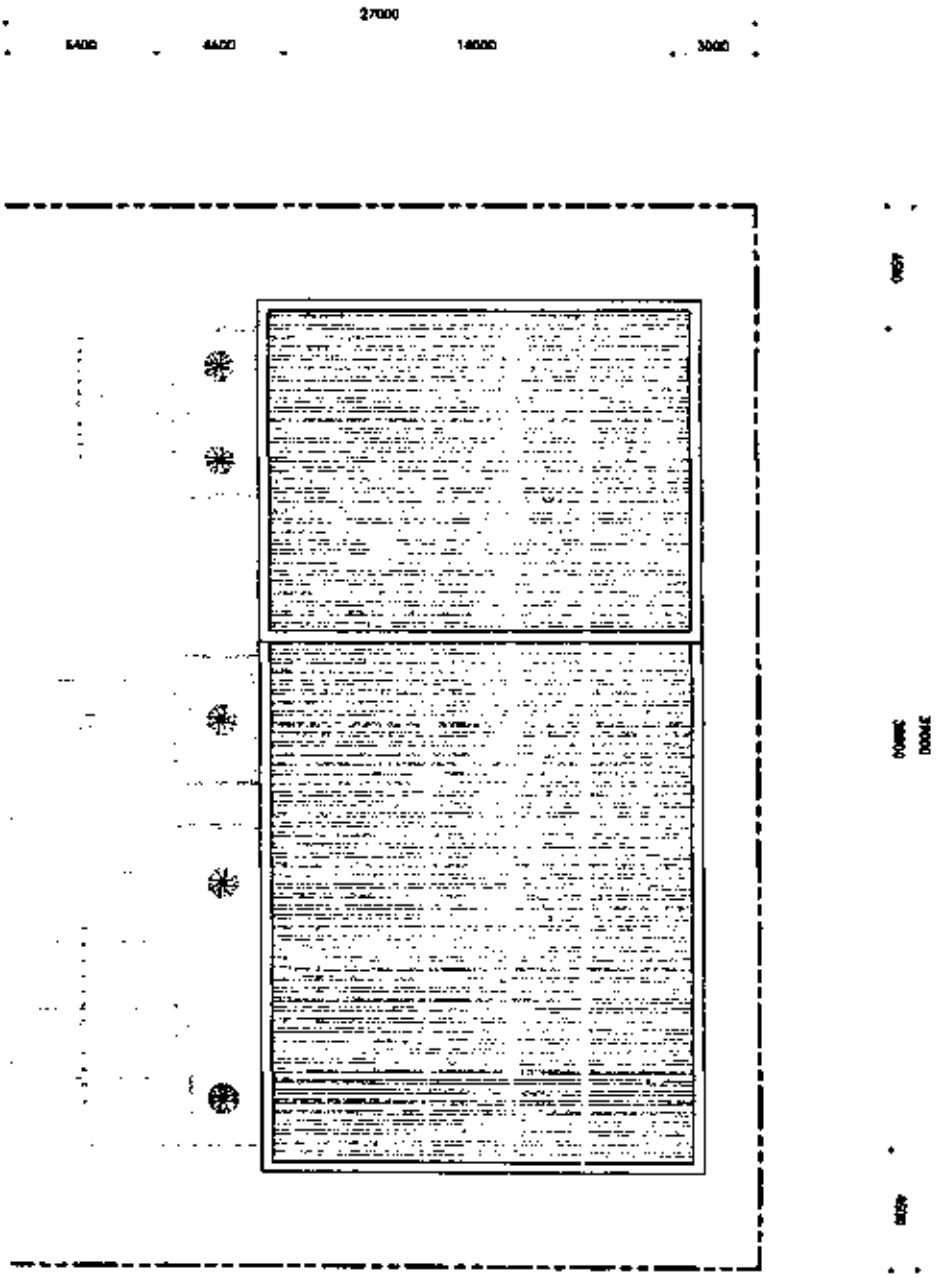

THE INTERNATIONAL BROTHERHOOD OF TEAMSTERS
SITE DEVELOPMENT PLAN
1975

PLANNING BY: ARCHITECT: d. v. [unclear]	REG. NO.: VALID UNTIL: PTN. NO.: DATE: TRK. NO.: PLACE:	OWNER: NERCO B. ANKA-1	PROJECT: PROPOSED THREE-STORY BUILDING (KALAYFA, ALJEVA EQLIA)	SHEET CONTAINS: FLOOR PLANS	DRAWING NO.: A-02
<small> This plan was prepared by the architect named above and is subject to the provisions of the Building Code of the City of Los Angeles, California, and the rules and regulations of the Department of Building and Safety, City of Los Angeles, California. It is not to be construed as a contract or as a guarantee of any kind. The architect assumes no responsibility for the accuracy of the information furnished by the owner or for the results of the construction of the building shown on this plan. The architect's liability is limited to the professional services rendered by him or her. </small>		CADD BY: DW	DATE: 08/07/75		

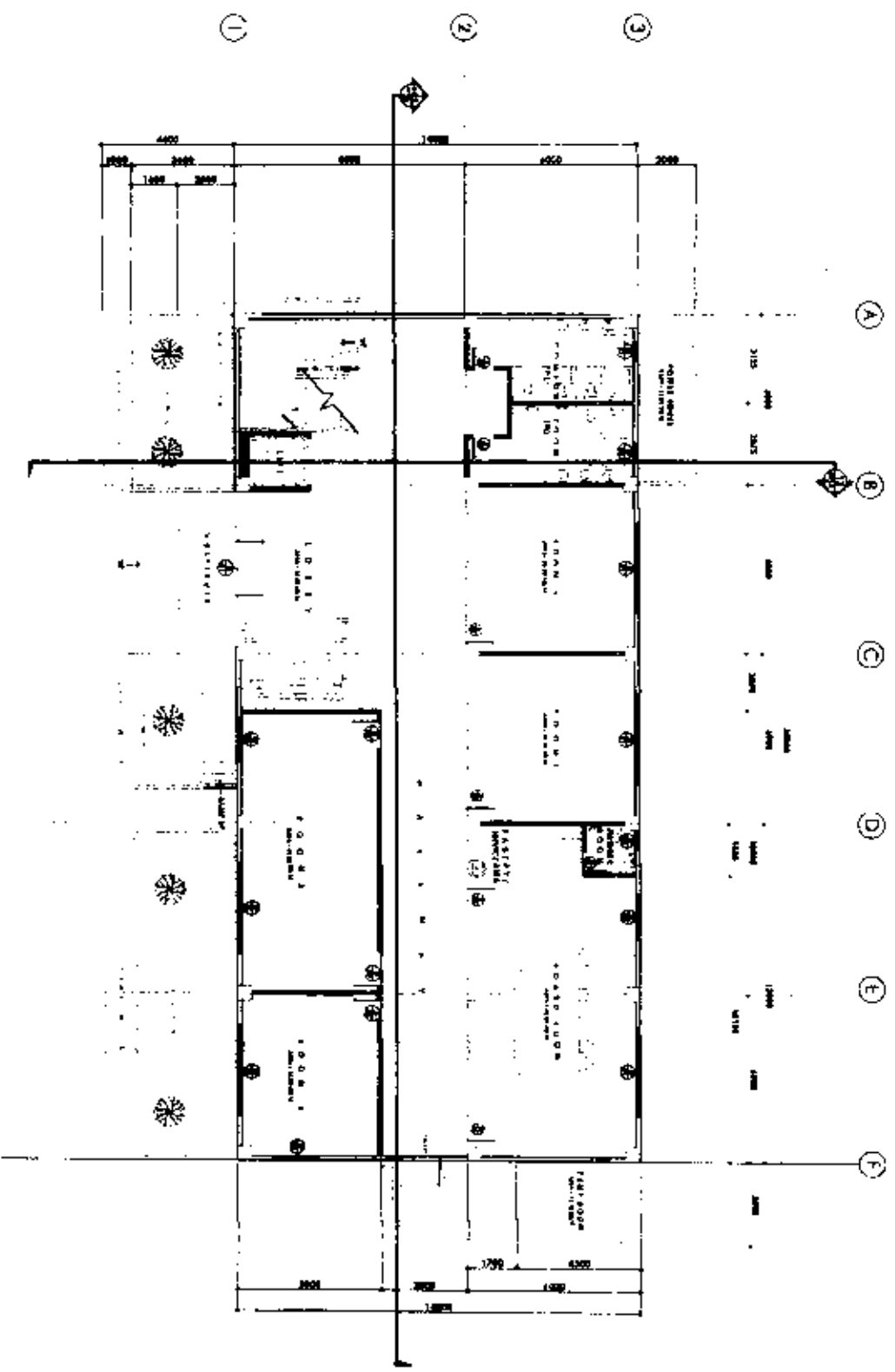



DEPARTMENT OF ARCHITECTURE
GROUND FLOOR PLAN
 1:1000

DESIGNER:	ENG. NO.:	OWNER:	PROJECT:	SHEET CONTINUA:	DRAWING NO.:
	VALID WRITE:	HECO & ASSOCIATES	PROPOSED THREE-STORY BUILDING TALAYERN, NARAYANECUA	ROOM 1-1	A-03
ARCHITECT:	DATE:			ROOM 1-2	DATE:
d.v. VILLARREAL <small>REGISTERED ARCHITECT</small>	SCALE:			ROOM 1-3	DATE:

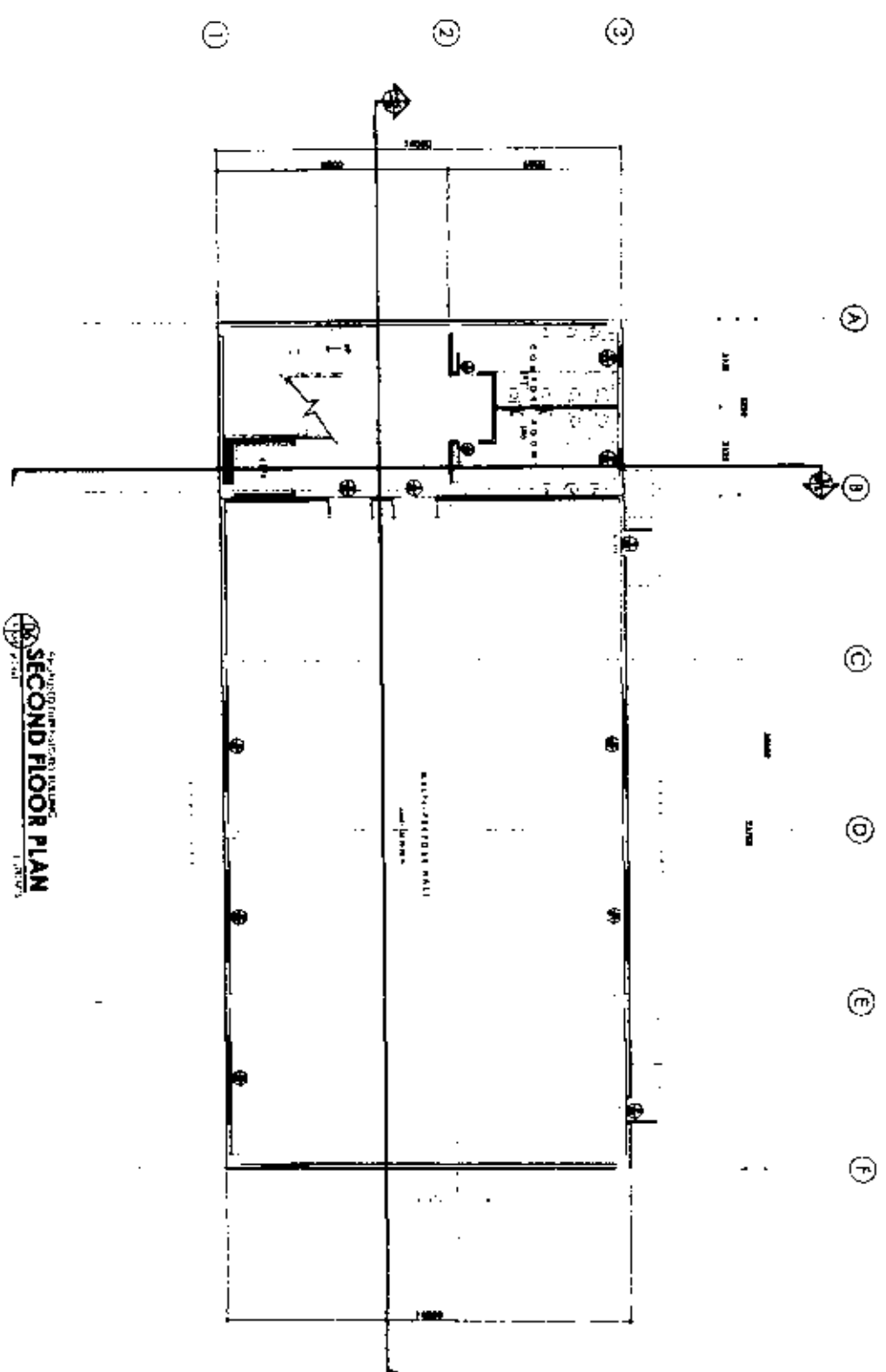

STATE OF NEVADA
 DEPARTMENT OF BUILDING AND CONSTRUCTION
SECOND FLOOR PLAN
 1.0000

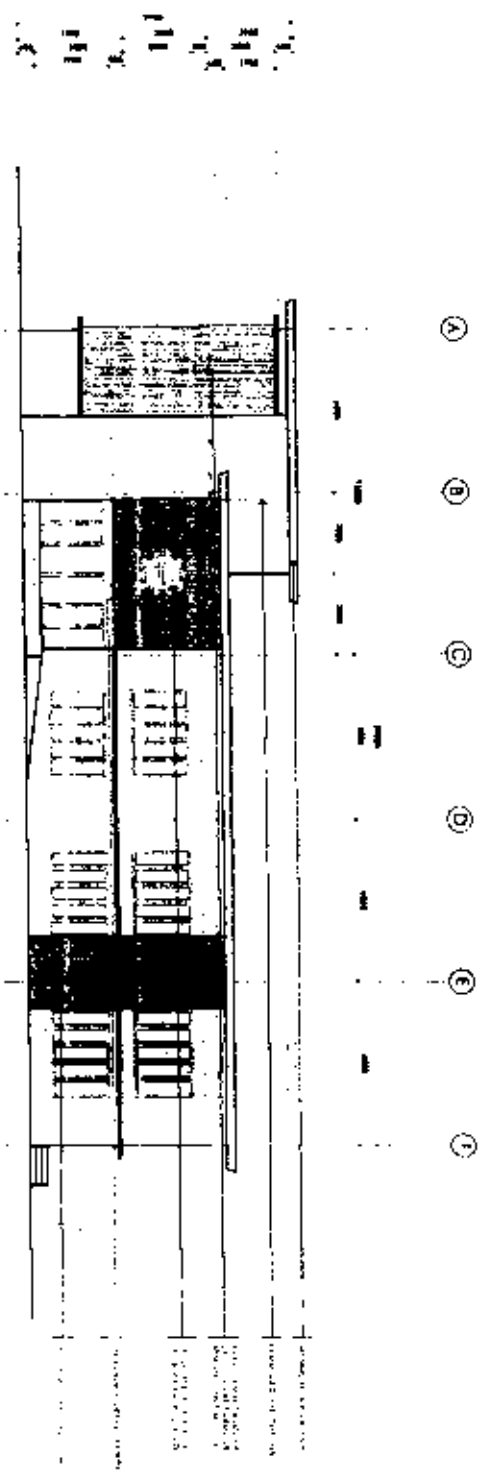

OWNER HERCO II AREA I		PROJECT PROPOSED THREE STORY BUILDING PALMVIEW, NEVADA CITY		FLOOR PLAN DWG. SHEET NO.	
ARCHITECT D. V. [unreadable] ARCHITECTS		DATE [unreadable]		DATE 2013.07.10	
REQ. NO. [unreadable]		DATE [unreadable]		DATE [unreadable]	
PLAN NO. [unreadable]		DATE [unreadable]		DATE [unreadable]	

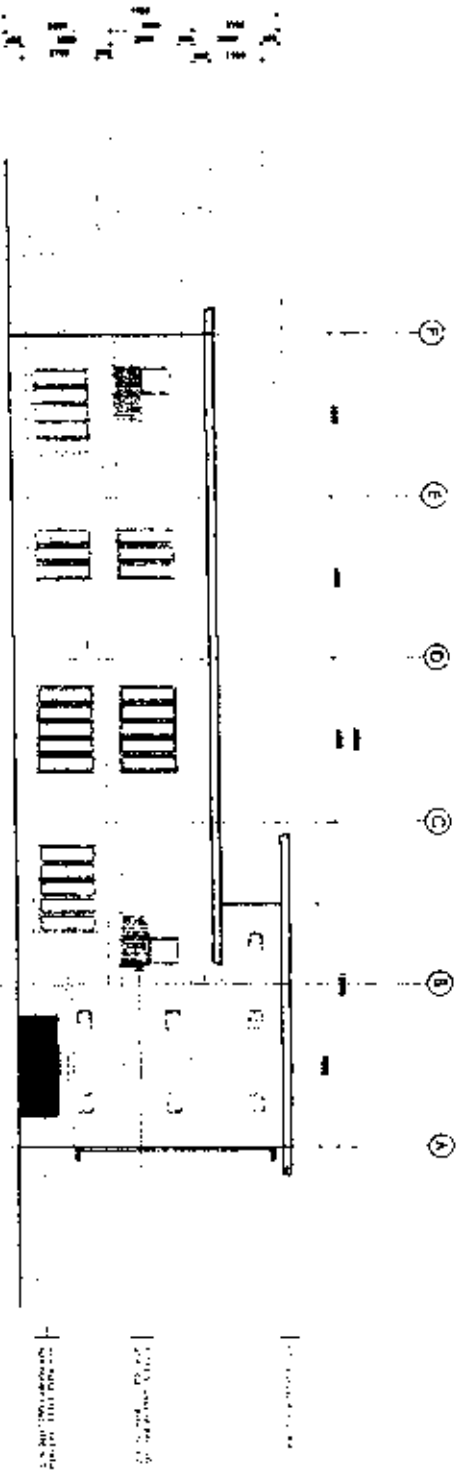

FRONT ELEVATION



REAR ELEVATION

ISSUED BY:	REG. NO.:	OWNER:	PROJECT:	SHEET CONTAINS:	DWG./SHEET NO.:
ARCHITECT:	VALID PERM.:	HISCO & ASSOC.	PROPOSED THREE-STORY BUILDING TALAVERA, NUEVA ESCUA	REVISIONS:	
	DATE:			CADD BY: D.M.	DATE: 2015.07.16
D. VILLALBA	PLACE:				

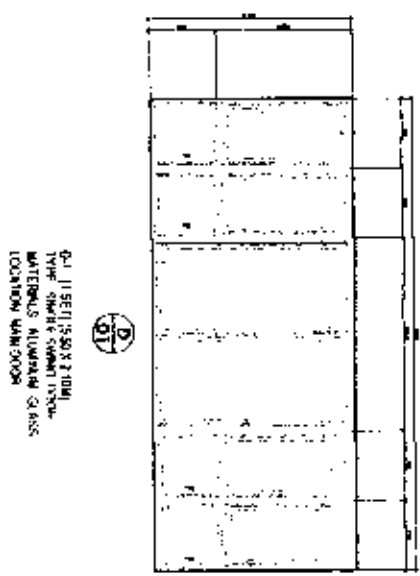

D1
 01 SETS 1.50 X 2.10M
 TYPE: SINGLE SWING DOOR
 MATERIALS: ALUMINUM GLASS
 LOCATION: MAIN ROOM



D2
 02 SETS 1.00 X 2.10M
 TYPE: SINGLE SWING DOOR
 MATERIALS: ALUMINUM GLASS
 LOCATION: STORAGE



D3
 03 SETS 1.00 X 2.10M
 TYPE: SINGLE SWING DOOR
 MATERIALS: ALUMINUM GLASS
 LOCATION: CORRIDOR ROOMS

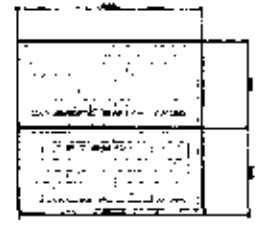

D4
 04 SETS 1.50 X 2.10M
 TYPE: DOUBLE SWING DOOR
 MATERIALS: ALUMINUM GLASS
 LOCATION: MULTI-PURPOSE HALL



D5
 05 SETS 1.00 X 2.10M
 TYPE: SINGLE SWING DOOR
 MATERIALS: ALUMINUM GLASS
 LOCATION: LIFT SHAFT



D6
 06 SETS 1.00 X 2.10M
 TYPE: SINGLE SWING DOOR
 MATERIALS: ALUMINUM GLASS
 LOCATION: GUEST ROOMS

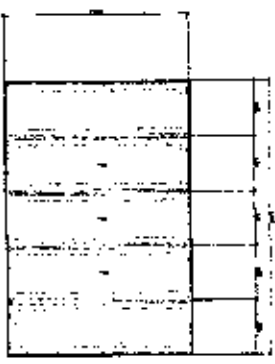

W1
 01 SETS 1.50 X 2.10M
 TYPE: CASSETTE FOLD
 MATERIALS: ALUMINUM GLASS
 LOCATION: MAIN ROOM

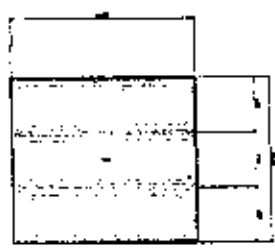

W2
 02 SETS 1.00 X 2.10M
 TYPE: CASSETTE FOLD
 MATERIALS: ALUMINUM GLASS
 LOCATION: MAIN ROOM



W3
 03 SETS 0.70 X 0.90M
 TYPE: CASSETTE FOLD
 MATERIALS: ALUMINUM GLASS
 LOCATION: MAIN ROOM



W4
 04 SETS 1.00 X 2.10M
 TYPE: CASSETTE FOLD
 MATERIALS: ALUMINUM GLASS
 LOCATION: MAIN ROOM

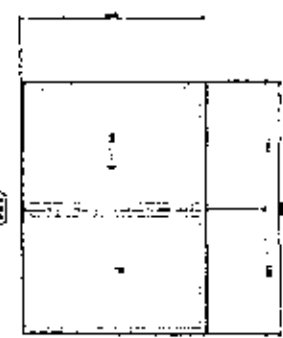

W5
 05 SETS 1.50 X 2.10M
 TYPE: CASSETTE FOLD
 MATERIALS: ALUMINUM GLASS
 LOCATION: THIRD FLOOR

1/A
 A/D/B SCALE
SCHEDULE OF DOORS & WINDOWS
 1:100 MTS

ISSUED BY:	REG. NO.:	DATE:	SCALE:
DESIGNED BY:	DATE:	SCALE:	
CHECKED BY:	DATE:	SCALE:	
APPROVED BY:	DATE:	SCALE:	
PROJECT:		SHEET NO.:	
PROPOSED THREE-STORY BUILDING DANANG, VIETNAM		A-08	
DRAWN BY:		DATE:	
D. V. TRAN		2023/7/18	

STRUCTURAL NOTES

A. GENERAL NOTES

1. ALL DIMENSIONS UNLESS OTHERWISE SPECIFIED SHALL BE IN FEET AND INCHES.
2. FOUNDATIONS SHALL BE CONSTRUCTED TO BE PROTECTED FROM FLOODING AND SHALL BE PROTECTED FROM COLLAPSE IN THE EVENT OF COLLAPSE OF THE STRUCTURE ABOVE.
3. THE CONSTRUCTION SHALL BE IN ACCORDANCE WITH THE LATEST EDITIONS OF THE FOLLOWING CODES AND STANDARDS:
 - a. ACI 308R-80, CONCRETE REINFORCING STEEL AND CONCRETE
 - b. ACI 309-80, CONSTRUCTION OF CONCRETE
 - c. ACI 318-88, BUILDING CODE REQUIREMENTS FOR STRUCTURAL CONCRETE
 - d. ACI 315-88, BUILDING CODE REQUIREMENTS FOR STRUCTURAL STEEL
 - e. ACI 312-88, BUILDING CODE REQUIREMENTS FOR STRUCTURAL ALUMINUM
 - f. ACI 308-80, CONCRETE REINFORCING STEEL AND CONCRETE
 - g. ACI 309-80, CONSTRUCTION OF CONCRETE
 - h. ACI 318-88, BUILDING CODE REQUIREMENTS FOR STRUCTURAL CONCRETE
 - i. ACI 315-88, BUILDING CODE REQUIREMENTS FOR STRUCTURAL STEEL
 - j. ACI 312-88, BUILDING CODE REQUIREMENTS FOR STRUCTURAL ALUMINUM
4. ALL DIMENSIONS SHALL BE TO FACE UNLESS OTHERWISE SPECIFIED.
5. ALL DIMENSIONS SHALL BE TO FACE UNLESS OTHERWISE SPECIFIED.
6. ALL DIMENSIONS SHALL BE TO FACE UNLESS OTHERWISE SPECIFIED.
7. ALL DIMENSIONS SHALL BE TO FACE UNLESS OTHERWISE SPECIFIED.
8. ALL DIMENSIONS SHALL BE TO FACE UNLESS OTHERWISE SPECIFIED.
9. ALL DIMENSIONS SHALL BE TO FACE UNLESS OTHERWISE SPECIFIED.
10. ALL DIMENSIONS SHALL BE TO FACE UNLESS OTHERWISE SPECIFIED.
11. ALL DIMENSIONS SHALL BE TO FACE UNLESS OTHERWISE SPECIFIED.

B. REINFORCED CONCRETE NOTES

SCHEDULE OF STRUCTURAL CONCRETE 28-DAY COMPRESSIVE STRENGTH AND TYPES

Location	STRUCTURAL ELEMENT	COMPRESSIVE STRENGTH	CONCRETE TYPE	MIN. SLAB
FOUNDATION	CONCRETE	4000 PSI	4100 (Type I)	4" (100mm)
FOUNDATION	CONCRETE	4000 PSI	4100 (Type I)	4" (100mm)
FOUNDATION	CONCRETE	4000 PSI	4100 (Type I)	4" (100mm)
FOUNDATION	CONCRETE	4000 PSI	4100 (Type I)	4" (100mm)
FOUNDATION	CONCRETE	4000 PSI	4100 (Type I)	4" (100mm)
FOUNDATION	CONCRETE	4000 PSI	4100 (Type I)	4" (100mm)
FOUNDATION	CONCRETE	4000 PSI	4100 (Type I)	4" (100mm)
FOUNDATION	CONCRETE	4000 PSI	4100 (Type I)	4" (100mm)
FOUNDATION	CONCRETE	4000 PSI	4100 (Type I)	4" (100mm)
FOUNDATION	CONCRETE	4000 PSI	4100 (Type I)	4" (100mm)

SCHEDULE OF CONCRETE AGGREGATES

Location	AGGREGATE SIZE	MIN. SLAB
FOUNDATION	3/4" (19 mm)	4" (100mm)
FOUNDATION	3/4" (19 mm)	4" (100mm)
FOUNDATION	3/4" (19 mm)	4" (100mm)
FOUNDATION	3/4" (19 mm)	4" (100mm)
FOUNDATION	3/4" (19 mm)	4" (100mm)
FOUNDATION	3/4" (19 mm)	4" (100mm)
FOUNDATION	3/4" (19 mm)	4" (100mm)
FOUNDATION	3/4" (19 mm)	4" (100mm)
FOUNDATION	3/4" (19 mm)	4" (100mm)
FOUNDATION	3/4" (19 mm)	4" (100mm)

1. ALL DIMENSIONS SHALL BE TO FACE UNLESS OTHERWISE SPECIFIED.
2. ALL DIMENSIONS SHALL BE TO FACE UNLESS OTHERWISE SPECIFIED.
3. ALL DIMENSIONS SHALL BE TO FACE UNLESS OTHERWISE SPECIFIED.
4. ALL DIMENSIONS SHALL BE TO FACE UNLESS OTHERWISE SPECIFIED.
5. ALL DIMENSIONS SHALL BE TO FACE UNLESS OTHERWISE SPECIFIED.
6. ALL DIMENSIONS SHALL BE TO FACE UNLESS OTHERWISE SPECIFIED.
7. ALL DIMENSIONS SHALL BE TO FACE UNLESS OTHERWISE SPECIFIED.
8. ALL DIMENSIONS SHALL BE TO FACE UNLESS OTHERWISE SPECIFIED.
9. ALL DIMENSIONS SHALL BE TO FACE UNLESS OTHERWISE SPECIFIED.
10. ALL DIMENSIONS SHALL BE TO FACE UNLESS OTHERWISE SPECIFIED.
11. ALL DIMENSIONS SHALL BE TO FACE UNLESS OTHERWISE SPECIFIED.

cast structural

ENRICO A. ANGELES

ENRICO A. ANGELES
 1000 S. GARDEN ST. #100
 LOS ANGELES, CALIF. 90006
 (213) 475-1111

ENRICO A. ANGELES
 1000 S. GARDEN ST. #100
 LOS ANGELES, CALIF. 90006
 (213) 475-1111

ENRICO A. ANGELES
 1000 S. GARDEN ST. #100
 LOS ANGELES, CALIF. 90006
 (213) 475-1111

ENRICO A. ANGELES
 1000 S. GARDEN ST. #100
 LOS ANGELES, CALIF. 90006
 (213) 475-1111

ENRICO A. ANGELES
 1000 S. GARDEN ST. #100
 LOS ANGELES, CALIF. 90006
 (213) 475-1111

C. REINFORCING STEEL

SCHEDULE OF REINFORCING BARS

DIAMETER OF BARS	GRADE (F)	ASTM
#11 AND SMALLER	GRADE 60 (ASTM A603)	A615/A618M (E60)
#14 AND LARGER	GRADE 60 (ASTM A603)	A615/A618M (E60)

SCHEDULE OF REINFORCING BARS

DIAMETER OF BARS	GRADE (F)	ASTM
#11 AND SMALLER	GRADE 60 (ASTM A603)	A615/A618M (E60)
#14 AND LARGER	GRADE 60 (ASTM A603)	A615/A618M (E60)

1. ALL DIMENSIONS SHALL BE TO FACE UNLESS OTHERWISE SPECIFIED.
2. ALL DIMENSIONS SHALL BE TO FACE UNLESS OTHERWISE SPECIFIED.
3. ALL DIMENSIONS SHALL BE TO FACE UNLESS OTHERWISE SPECIFIED.
4. ALL DIMENSIONS SHALL BE TO FACE UNLESS OTHERWISE SPECIFIED.
5. ALL DIMENSIONS SHALL BE TO FACE UNLESS OTHERWISE SPECIFIED.
6. ALL DIMENSIONS SHALL BE TO FACE UNLESS OTHERWISE SPECIFIED.
7. ALL DIMENSIONS SHALL BE TO FACE UNLESS OTHERWISE SPECIFIED.
8. ALL DIMENSIONS SHALL BE TO FACE UNLESS OTHERWISE SPECIFIED.
9. ALL DIMENSIONS SHALL BE TO FACE UNLESS OTHERWISE SPECIFIED.
10. ALL DIMENSIONS SHALL BE TO FACE UNLESS OTHERWISE SPECIFIED.
11. ALL DIMENSIONS SHALL BE TO FACE UNLESS OTHERWISE SPECIFIED.

cast structural

ENRICO A. ANGELES

ENRICO A. ANGELES
 1000 S. GARDEN ST. #100
 LOS ANGELES, CALIF. 90006
 (213) 475-1111

ENRICO A. ANGELES
 1000 S. GARDEN ST. #100
 LOS ANGELES, CALIF. 90006
 (213) 475-1111

ENRICO A. ANGELES
 1000 S. GARDEN ST. #100
 LOS ANGELES, CALIF. 90006
 (213) 475-1111

ENRICO A. ANGELES
 1000 S. GARDEN ST. #100
 LOS ANGELES, CALIF. 90006
 (213) 475-1111

E. FORMWORKS

1. ALL DIMENSIONS SHALL BE TO FACE UNLESS OTHERWISE SPECIFIED.
2. ALL DIMENSIONS SHALL BE TO FACE UNLESS OTHERWISE SPECIFIED.
3. ALL DIMENSIONS SHALL BE TO FACE UNLESS OTHERWISE SPECIFIED.
4. ALL DIMENSIONS SHALL BE TO FACE UNLESS OTHERWISE SPECIFIED.
5. ALL DIMENSIONS SHALL BE TO FACE UNLESS OTHERWISE SPECIFIED.
6. ALL DIMENSIONS SHALL BE TO FACE UNLESS OTHERWISE SPECIFIED.
7. ALL DIMENSIONS SHALL BE TO FACE UNLESS OTHERWISE SPECIFIED.
8. ALL DIMENSIONS SHALL BE TO FACE UNLESS OTHERWISE SPECIFIED.
9. ALL DIMENSIONS SHALL BE TO FACE UNLESS OTHERWISE SPECIFIED.
10. ALL DIMENSIONS SHALL BE TO FACE UNLESS OTHERWISE SPECIFIED.
11. ALL DIMENSIONS SHALL BE TO FACE UNLESS OTHERWISE SPECIFIED.

E. FORMWORKS

SCHEDULE OF FORMWORKS

ITEM	TIME
FOUNDATION	24 HRS
FOUNDATION	24 HRS
FOUNDATION	24 HRS
FOUNDATION	24 HRS
FOUNDATION	24 HRS
FOUNDATION	24 HRS
FOUNDATION	24 HRS
FOUNDATION	24 HRS
FOUNDATION	24 HRS
FOUNDATION	24 HRS

SCHEDULE OF FORMWORKS

ITEM	TIME
FOUNDATION	24 HRS
FOUNDATION	24 HRS
FOUNDATION	24 HRS
FOUNDATION	24 HRS
FOUNDATION	24 HRS
FOUNDATION	24 HRS
FOUNDATION	24 HRS
FOUNDATION	24 HRS
FOUNDATION	24 HRS
FOUNDATION	24 HRS

1. ALL DIMENSIONS SHALL BE TO FACE UNLESS OTHERWISE SPECIFIED.
2. ALL DIMENSIONS SHALL BE TO FACE UNLESS OTHERWISE SPECIFIED.
3. ALL DIMENSIONS SHALL BE TO FACE UNLESS OTHERWISE SPECIFIED.
4. ALL DIMENSIONS SHALL BE TO FACE UNLESS OTHERWISE SPECIFIED.
5. ALL DIMENSIONS SHALL BE TO FACE UNLESS OTHERWISE SPECIFIED.
6. ALL DIMENSIONS SHALL BE TO FACE UNLESS OTHERWISE SPECIFIED.
7. ALL DIMENSIONS SHALL BE TO FACE UNLESS OTHERWISE SPECIFIED.
8. ALL DIMENSIONS SHALL BE TO FACE UNLESS OTHERWISE SPECIFIED.
9. ALL DIMENSIONS SHALL BE TO FACE UNLESS OTHERWISE SPECIFIED.
10. ALL DIMENSIONS SHALL BE TO FACE UNLESS OTHERWISE SPECIFIED.
11. ALL DIMENSIONS SHALL BE TO FACE UNLESS OTHERWISE SPECIFIED.

cast structural

ENRICO A. ANGELES

ENRICO A. ANGELES
 1000 S. GARDEN ST. #100
 LOS ANGELES, CALIF. 90006
 (213) 475-1111

ENRICO A. ANGELES
 1000 S. GARDEN ST. #100
 LOS ANGELES, CALIF. 90006
 (213) 475-1111

ENRICO A. ANGELES
 1000 S. GARDEN ST. #100
 LOS ANGELES, CALIF. 90006
 (213) 475-1111

SCHEDULE OF STRUCTURAL CONCRETE

RC COLUMN & STEEL COLUMN SCHEDULE

COLUMN DESIGNATION	DIMENSION (mm/a x b)	SECTION	VERTICAL BARS	LATERAL TIES	REMARKS
C1	400 x 400	□	DB - 20mm @ 12 - 20mm @	YES 10mm	DOUBLE TIES
C2	450 x 450	□	DB - 20mm @ 12 - 20mm @	YES 10mm	DOUBLE TIES

RC FOOTING SCHEDULE

FOOTING DESIGNATION	L1 mm.	L2 mm.	I mm.	C1 mm.	C2 mm.	D1 mm.	FR 1	FR 2	GRAVEL
F1	1,500.00	1,500.00	400.00			2,000.00	13-20mm @	13-20mm @	75mm thk
F2	2,000.00	2,000.00	400.00			2,000.00	15-20mm @	15-20mm @	75mm thk

RC BEAM & STEEL BEAM SCHEDULE

DESIGNATION	B x D mm.	AT LEFT SUPPORT		AT MIDDLE		AT RIGHT SUPPORT		REMARKS
		TOP	BOTTOM	TOP	BOTTOM	TOP	BOTTOM	
FTB	200 x 400	6-14mm @	3-14mm @	3-14mm @	3-14mm @	6-14mm @	3-14mm @	
GFB	200 x 400	6-14mm @	3-14mm @	3-14mm @	3-14mm @	6-14mm @	3-14mm @	
B1	200 x 400	3-20mm @	3-20mm @	3-20mm @	3-20mm @	3-20mm @	3-20mm @	
B2	200 x 400	3-20mm @	3-20mm @	3-20mm @	3-20mm @	3-20mm @	3-20mm @	
B3	200 x 400	3-20mm @	3-20mm @	3-20mm @	3-20mm @	3-20mm @	3-20mm @	
B4	200 x 400	3-20mm @	3-20mm @	3-20mm @	3-20mm @	3-20mm @	3-20mm @	
RB	300 x 600	6-20mm @	3-20mm @	3-20mm @	3-20mm @	6-20mm @	3-20mm @	

MARK	TYPE	THK.	SPECIFICATIONS
S-1	SLAB ON STEEL DECK	125mm	SLAB ON STEEL DECK SPAN 1.1mm WITH 81mm BARS SPACED @ 300mm O.C. BOTHWAYS
S-3	SLAB ON FILL	125mm	81mm BARS SPACED @ 300mm O.C. BOTHWAYS

Structural

ENRICO A. ANGELES

CONSTRUCTION DEPARTMENT BUILDING

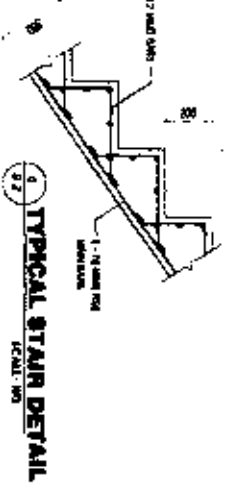
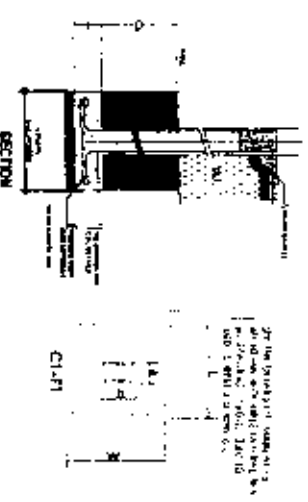
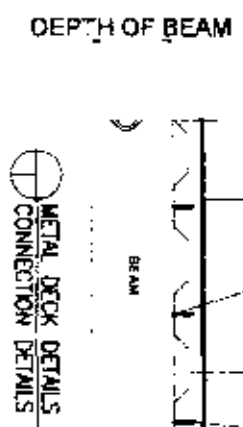
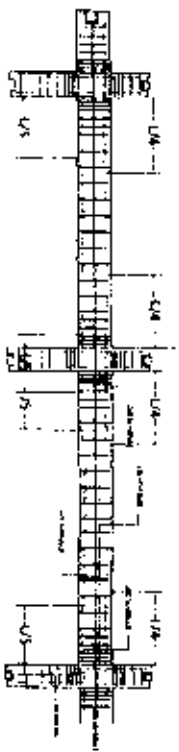

SCALE

NEIGHBORHOOD

S2

02 07

A B C D E F G H I J

1 2 3 4 5 6 7



SCALE 1:100 M

eaststructural

ENRICO A. ANGELES

PROJECT: ARCHITECTURE STRUCTURAL ENGINEERING MECHANICAL ENGINEERING ELECTRICAL ENGINEERING CIVIL ENGINEERING ENVIRONMENTAL ENGINEERING
 DRAWING NO.: ARCHITECTURE STRUCTURAL ENGINEERING MECHANICAL ENGINEERING ELECTRICAL ENGINEERING CIVIL ENGINEERING ENVIRONMENTAL ENGINEERING
 SHEET NO.: ARCHITECTURE STRUCTURAL ENGINEERING MECHANICAL ENGINEERING ELECTRICAL ENGINEERING CIVIL ENGINEERING ENVIRONMENTAL ENGINEERING
 DATE: ARCHITECTURE STRUCTURAL ENGINEERING MECHANICAL ENGINEERING ELECTRICAL ENGINEERING CIVIL ENGINEERING ENVIRONMENTAL ENGINEERING

A B C D E F G H I J

1 2 3 4 5 6 7

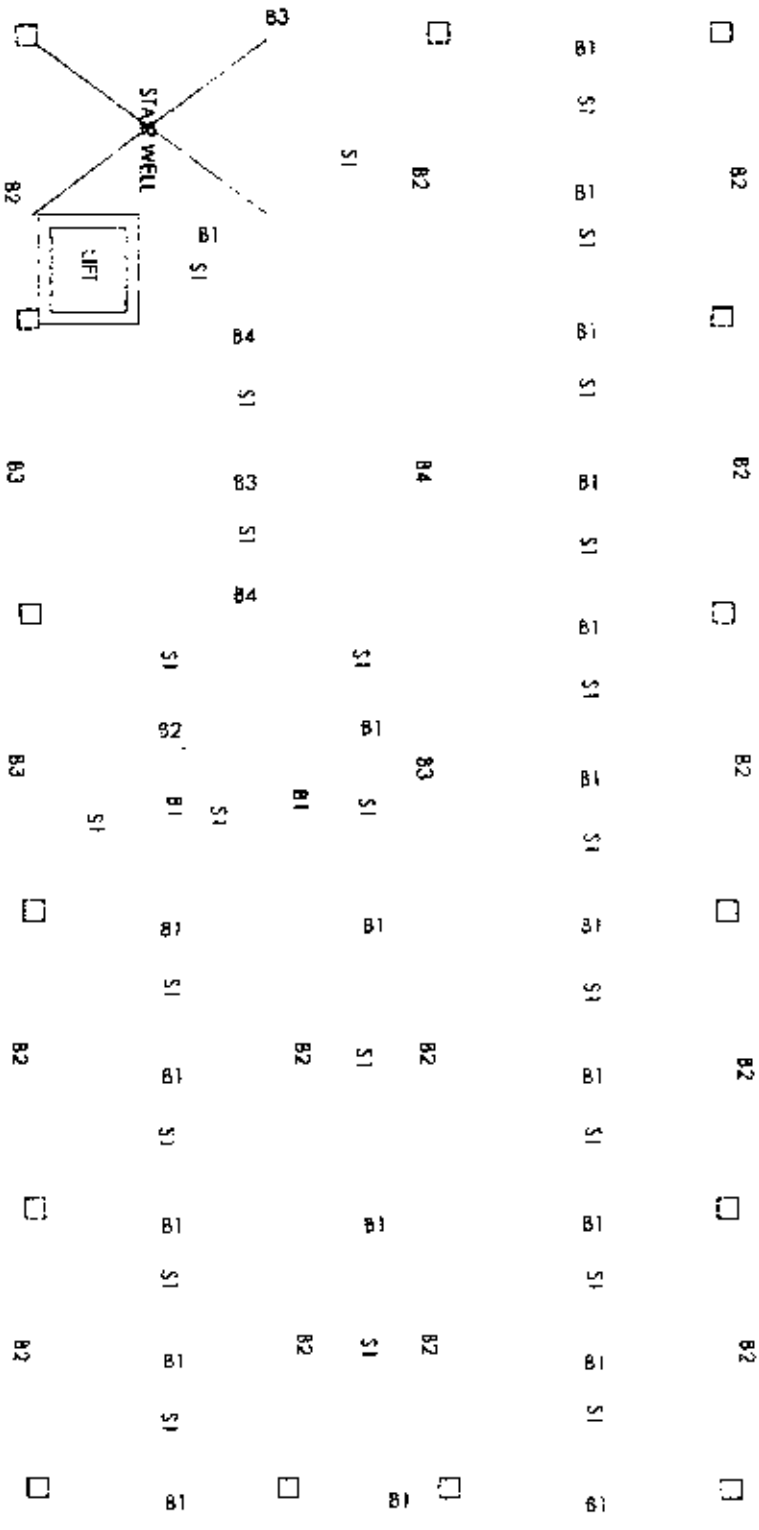

eaststructural

ENRICO A. ANGELES

PROJECT NO.	DATE	SCALE	STATUS
PROJECT NAME	DATE	SCALE	STATUS
PROJECT ADDRESS	DATE	SCALE	STATUS
PROJECT CITY	DATE	SCALE	STATUS
PROJECT STATE	DATE	SCALE	STATUS
PROJECT ZIP	DATE	SCALE	STATUS

A B C D E F G H I J

1 2 3 4 5 6 7

10 50mm X 100mm X 1.5mm PLATE
SPACED @ 500mm O.C.

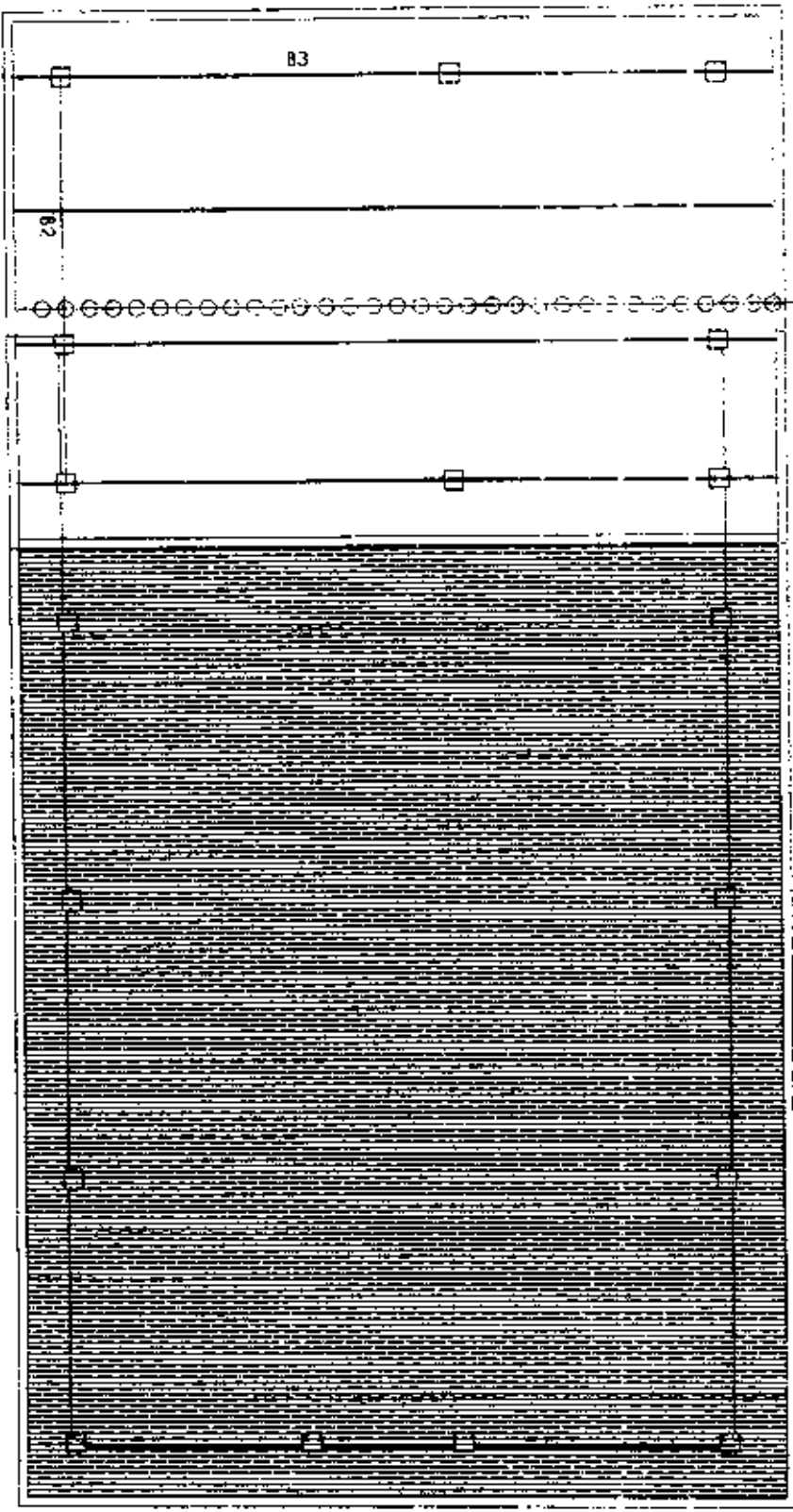

SCALE 1:100M

castructural

ENRICO A. ANGELES

PROJECT NO.	DATE	SCALE	REVISION

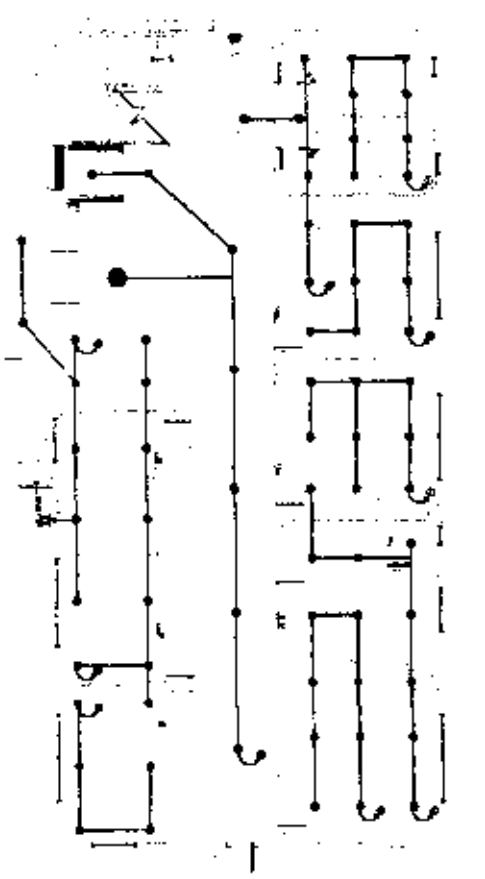

GROUND FLOOR LIGHTING LAY-OUT

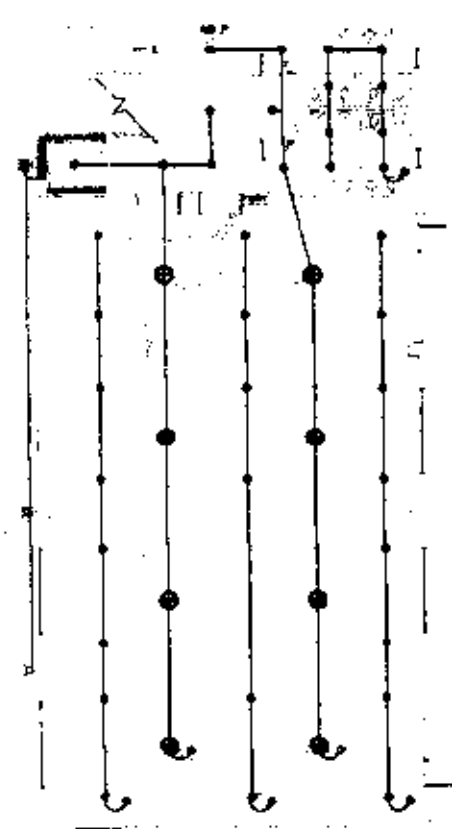

SECOND FLOOR LIGHTING LAY-OUT

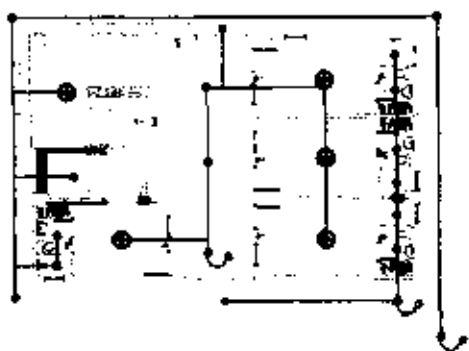

THIRD FLOOR LIGHTING LAY-OUT

ISSUED BY:	REC. NO.:	OWNER:	PROJECT:	SHEET CONTENTS:	DWG./SHEET NO.:
PROFESSIONAL ELECTRICAL ENGINEER	VALID LINK:	MERCOSARMA4	PROPOSED THIRD-STORY BUILDING TALAVERA, MEXICO/COLIA	LIGHTING LAY-OUT	E-01
DATE:	DATE:			CADD BY:	DATE:
PLACE:				Q. VA	2023/1/10

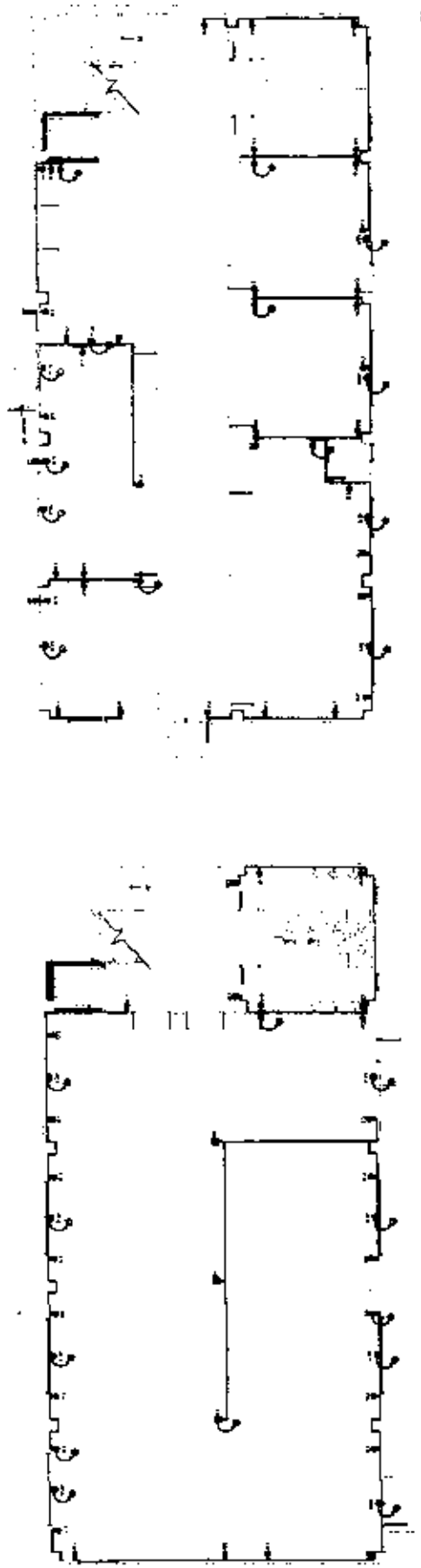

1
 GROUND FLOOR POWER LAY-OUT



THIRD FLOOR POWER LAY-OUT

SECOND FLOOR POWER LAY-OUT

DESIGNED BY:	REQ. NO.:	OWNER:	PROJECT:	SHEET CONTAINS:	DWG. SHEET NO.:
PROFESSIONAL ELECTRICAL ENGINEER	VALID UNTIL:	ARCO II ASFAI	PROPOSED THREE-STORY BUILDING TALAVERA, SALINA ECUA	POWER LAY-OUT	E-02
D. VILCHES SUAREZ	DATE:			CADD BY:	DATE:
REGISTERED ELECTRICAL ENGINEER	PLACE:			D.H.	2023/7/18

PANEL BOARD 1

CRT NO.	LOAD DESCRIPTION	NO. OF CIRCUITS	WATTS	VOLTS	AMPERE	CRT PROTECTION	WIRE SIZE	CONDUIT
1	LIGHTING	2	321	120	1.35	20 A	2 - 30mm ² THHN	50x50
2	LIGHTING	2	321	120	1.35	20 A	2 - 30mm ² THHN	50x50
3	LIGHTING	2	321	120	1.35	20 A	2 - 30mm ² THHN	50x50
4	LIGHTING	2	321	120	1.35	20 A	2 - 30mm ² THHN	50x50
5	LIGHTING	2	321	120	1.35	20 A	2 - 30mm ² THHN	50x50
6	LIGHTING	2	321	120	1.35	20 A	2 - 30mm ² THHN	50x50
7	LIGHTING	2	321	120	1.35	20 A	2 - 30mm ² THHN	50x50
8	LIGHTING	2	321	120	1.35	20 A	2 - 30mm ² THHN	50x50
9	LIGHTING	2	321	120	1.35	20 A	2 - 30mm ² THHN	50x50
10	LIGHTING	2	321	120	1.35	20 A	2 - 30mm ² THHN	50x50
11	CON. SERVICE CABLE	1	400	200	1.66	20 A	2 - 30mm ² THHN	50x50
12	CON. SERVICE CABLE	1	400	200	1.66	20 A	2 - 30mm ² THHN	50x50
13	CON. SERVICE CABLE	1	400	200	1.66	20 A	2 - 30mm ² THHN	50x50
14	CON. SERVICE CABLE	1	400	200	1.66	20 A	2 - 30mm ² THHN	50x50
15	CON. SERVICE CABLE	1	400	200	1.66	20 A	2 - 30mm ² THHN	50x50
16	CON. SERVICE CABLE	1	400	200	1.66	20 A	2 - 30mm ² THHN	50x50
17	CON. SERVICE CABLE	1	400	200	1.66	20 A	2 - 30mm ² THHN	50x50
18	CON. SERVICE CABLE	1	400	200	1.66	20 A	2 - 30mm ² THHN	50x50
19	CON. SERVICE CABLE	1	400	200	1.66	20 A	2 - 30mm ² THHN	50x50
20	CON. SERVICE CABLE	1	400	200	1.66	20 A	2 - 30mm ² THHN	50x50
21	CON. SERVICE CABLE	1	400	200	1.66	20 A	2 - 30mm ² THHN	50x50
22	CON. SERVICE CABLE	1	400	200	1.66	20 A	2 - 30mm ² THHN	50x50
23	CON. SERVICE CABLE	1	400	200	1.66	20 A	2 - 30mm ² THHN	50x50
24	CON. SERVICE CABLE	1	400	200	1.66	20 A	2 - 30mm ² THHN	50x50
25	CON. SERVICE CABLE	1	400	200	1.66	20 A	2 - 30mm ² THHN	50x50
26	CON. SERVICE CABLE	1	400	200	1.66	20 A	2 - 30mm ² THHN	50x50
27	CON. SERVICE CABLE	1	400	200	1.66	20 A	2 - 30mm ² THHN	50x50
28	CON. SERVICE CABLE	1	400	200	1.66	20 A	2 - 30mm ² THHN	50x50
29	CON. SERVICE CABLE	1	400	200	1.66	20 A	2 - 30mm ² THHN	50x50
30	CON. SERVICE CABLE	1	400	200	1.66	20 A	2 - 30mm ² THHN	50x50
TOTAL			19 400		161.5A	200 A	2 - 30mm ² THHN	250mm ² PVC

$I = [140.36 \text{ AMP} + 25\% (12)] (85\%) = 171.77 \text{ AMP}$

PANEL BOARD 2

CRT NO.	LOAD DESCRIPTION	NO. OF CIRCUITS	WATTS	VOLTS	AMPERE	CRT PROTECTION	WIRE SIZE	CONDUIT
1	LIGHTING	1	160	120	0.67	20 A	2 - 30mm ² THHN	50x50
2	LIGHTING	1	160	120	0.67	20 A	2 - 30mm ² THHN	50x50
3	LIGHTING	1	160	120	0.67	20 A	2 - 30mm ² THHN	50x50
4	LIGHTING	1	160	120	0.67	20 A	2 - 30mm ² THHN	50x50
5	LIGHTING	1	160	120	0.67	20 A	2 - 30mm ² THHN	50x50
6	CON. SERVICE CABLE	1	400	200	1.66	20 A	2 - 30mm ² THHN	50x50
7	CON. SERVICE CABLE	1	400	200	1.66	20 A	2 - 30mm ² THHN	50x50
8	CON. SERVICE CABLE	1	400	200	1.66	20 A	2 - 30mm ² THHN	50x50
9	CON. SERVICE CABLE	1	400	200	1.66	20 A	2 - 30mm ² THHN	50x50
10	CON. SERVICE CABLE	1	400	200	1.66	20 A	2 - 30mm ² THHN	50x50
11	CON. SERVICE CABLE	1	400	200	1.66	20 A	2 - 30mm ² THHN	50x50
12	CON. SERVICE CABLE	1	400	200	1.66	20 A	2 - 30mm ² THHN	50x50
13	CON. SERVICE CABLE	1	400	200	1.66	20 A	2 - 30mm ² THHN	50x50
14	CON. SERVICE CABLE	1	400	200	1.66	20 A	2 - 30mm ² THHN	50x50
15	CON. SERVICE CABLE	1	400	200	1.66	20 A	2 - 30mm ² THHN	50x50
16	CON. SERVICE CABLE	1	400	200	1.66	20 A	2 - 30mm ² THHN	50x50
17	CON. SERVICE CABLE	1	400	200	1.66	20 A	2 - 30mm ² THHN	50x50
18	CON. SERVICE CABLE	1	400	200	1.66	20 A	2 - 30mm ² THHN	50x50
19	CON. SERVICE CABLE	1	400	200	1.66	20 A	2 - 30mm ² THHN	50x50
20	CON. SERVICE CABLE	1	400	200	1.66	20 A	2 - 30mm ² THHN	50x50
21	CON. SERVICE CABLE	1	400	200	1.66	20 A	2 - 30mm ² THHN	50x50
22	CON. SERVICE CABLE	1	400	200	1.66	20 A	2 - 30mm ² THHN	50x50
23	CON. SERVICE CABLE	1	400	200	1.66	20 A	2 - 30mm ² THHN	50x50
24	CON. SERVICE CABLE	1	400	200	1.66	20 A	2 - 30mm ² THHN	50x50
25	CON. SERVICE CABLE	1	400	200	1.66	20 A	2 - 30mm ² THHN	50x50
26	CON. SERVICE CABLE	1	400	200	1.66	20 A	2 - 30mm ² THHN	50x50
27	CON. SERVICE CABLE	1	400	200	1.66	20 A	2 - 30mm ² THHN	50x50
28	CON. SERVICE CABLE	1	400	200	1.66	20 A	2 - 30mm ² THHN	50x50
29	CON. SERVICE CABLE	1	400	200	1.66	20 A	2 - 30mm ² THHN	50x50
30	CON. SERVICE CABLE	1	400	200	1.66	20 A	2 - 30mm ² THHN	50x50
TOTAL			7 800		38.4A	200 A	2 - 30mm ² THHN	250mm ² PVC

$I = [255.61 \text{ AMP} + 25\% (12)] (85\%) = 272.36 \text{ AMP}$

PANEL BOARD 3

CRT NO.	LOAD DESCRIPTION	NO. OF CIRCUITS	WATTS	VOLTS	AMPERE	CRT PROTECTION	WIRE SIZE	CONDUIT
1	LIGHTING	3	321	120	1.35	20 A	2 - 30mm ² THHN	50x50
2	LIGHTING	3	321	120	1.35	20 A	2 - 30mm ² THHN	50x50
3	LIGHTING	3	321	120	1.35	20 A	2 - 30mm ² THHN	50x50
4	CON. SERVICE CABLE	1	400	200	1.66	20 A	2 - 30mm ² THHN	50x50
5	CON. SERVICE CABLE	1	400	200	1.66	20 A	2 - 30mm ² THHN	50x50
6	CON. SERVICE CABLE	1	400	200	1.66	20 A	2 - 30mm ² THHN	50x50
7	CON. SERVICE CABLE	1	400	200	1.66	20 A	2 - 30mm ² THHN	50x50
8	CON. SERVICE CABLE	1	400	200	1.66	20 A	2 - 30mm ² THHN	50x50
9	CON. SERVICE CABLE	1	400	200	1.66	20 A	2 - 30mm ² THHN	50x50
10	CON. SERVICE CABLE	1	400	200	1.66	20 A	2 - 30mm ² THHN	50x50
11	CON. SERVICE CABLE	1	400	200	1.66	20 A	2 - 30mm ² THHN	50x50
12	CON. SERVICE CABLE	1	400	200	1.66	20 A	2 - 30mm ² THHN	50x50
13	CON. SERVICE CABLE	1	400	200	1.66	20 A	2 - 30mm ² THHN	50x50
14	CON. SERVICE CABLE	1	400	200	1.66	20 A	2 - 30mm ² THHN	50x50
15	CON. SERVICE CABLE	1	400	200	1.66	20 A	2 - 30mm ² THHN	50x50
16	CON. SERVICE CABLE	1	400	200	1.66	20 A	2 - 30mm ² THHN	50x50
17	CON. SERVICE CABLE	1	400	200	1.66	20 A	2 - 30mm ² THHN	50x50
18	CON. SERVICE CABLE	1	400	200	1.66	20 A	2 - 30mm ² THHN	50x50
19	CON. SERVICE CABLE	1	400	200	1.66	20 A	2 - 30mm ² THHN	50x50
20	CON. SERVICE CABLE	1	400	200	1.66	20 A	2 - 30mm ² THHN	50x50
21	CON. SERVICE CABLE	1	400	200	1.66	20 A	2 - 30mm ² THHN	50x50
22	CON. SERVICE CABLE	1	400	200	1.66	20 A	2 - 30mm ² THHN	50x50
23	CON. SERVICE CABLE	1	400	200	1.66	20 A	2 - 30mm ² THHN	50x50
24	CON. SERVICE CABLE	1	400	200	1.66	20 A	2 - 30mm ² THHN	50x50
25	CON. SERVICE CABLE	1	400	200	1.66	20 A	2 - 30mm ² THHN	50x50
26	CON. SERVICE CABLE	1	400	200	1.66	20 A	2 - 30mm ² THHN	50x50
27	CON. SERVICE CABLE	1	400	200	1.66	20 A	2 - 30mm ² THHN	50x50
28	CON. SERVICE CABLE	1	400	200	1.66	20 A	2 - 30mm ² THHN	50x50
29	CON. SERVICE CABLE	1	400	200	1.66	20 A	2 - 30mm ² THHN	50x50
30	CON. SERVICE CABLE	1	400	200	1.66	20 A	2 - 30mm ² THHN	50x50
TOTAL			4 800		58.5A	200 A	2 - 30mm ² THHN	250mm ² PVC

$I = [55.80 \text{ AMP} + 25\% (12)] (85\%) = 49.55 \text{ AMP}$

$I = (I1) + (I2) + (I3)$
 $I = 171.77 + 272.36 + 49.55$
 $I = 393.68 \text{ AMP}$

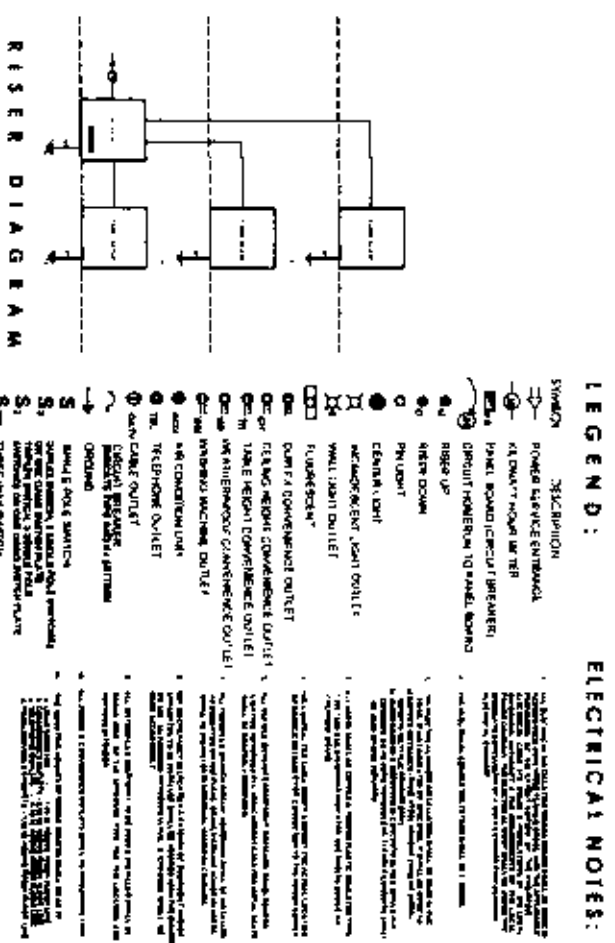

ISSUED BY:	DESIGN NO.:	OWNER:	PROJECT:	LOAD CONTINUED:	DWG. SHEET NO.:
PROFESSIONAL ELECTRICAL ENGINEER	VALID UNTIL:	MICRO 8 AREA 1	PROPOSED THREE STOREY BUILDING	RISE DIAGRAM	E-03
DATE:	DATE:	TALAVERA, NEVA EQUA			
TH NO.:	TH NO.:				
PLACE:	PLACE:				
DATE:	DATE:				

PROPOSED THIRD FLOOR PLAN
GROUND FLOOR CWL LAYOUT

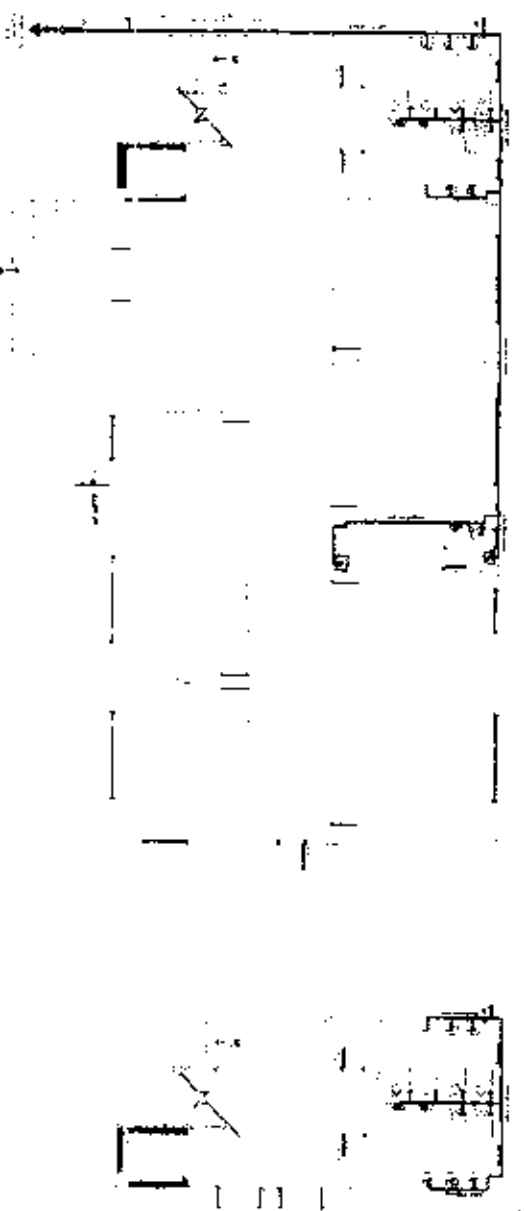

PROPOSED THIRD FLOOR PLAN
SECOND FLOOR CWL LAYOUT

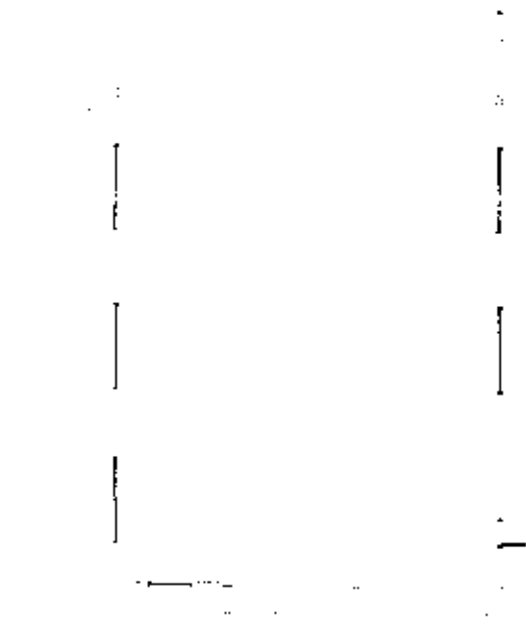

PROPOSED THIRD FLOOR PLAN
THIRD FLOOR CWL LAYOUT

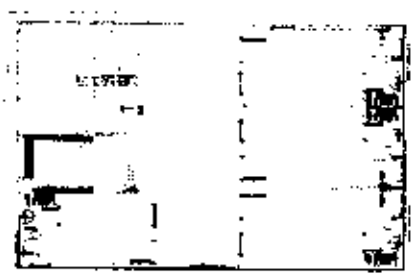

Q1200 ST.	REG. NO.	CHARGE	PROJECT	SHEET CONTAINS:	SWF SHEET NO.
RECORDED MASTER PLUMBER	VALID DATE:	NECO 1 AREA 1	PROPOSED THREE STOREY BUILDING 1/A/VERA, NEVA ECIL	CWL LAY-OUT	P-01
d. V. JAYARAMAN REGISTERED MASTER PLUMBER	DATE:			CADD BY: D. V.	DATE: 2012.07.18
	ISS. NO.:				
	PLACE:				

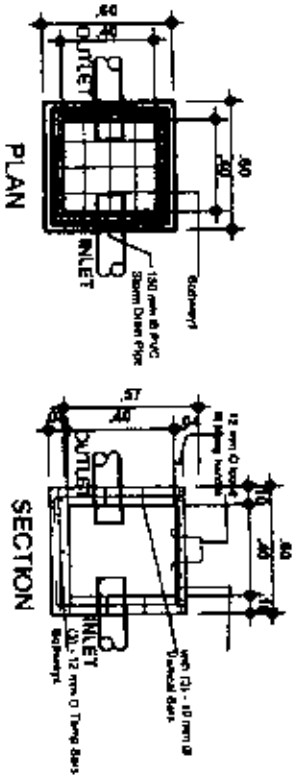
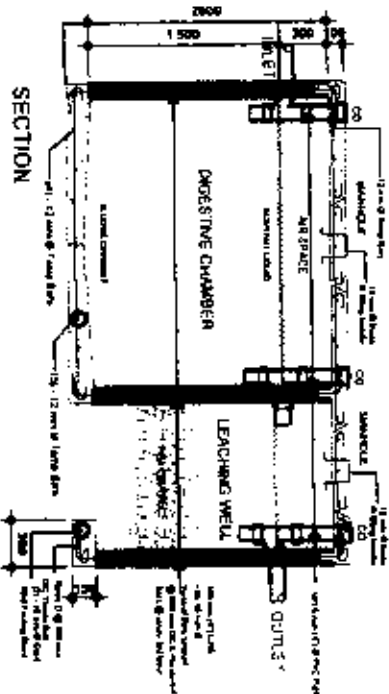
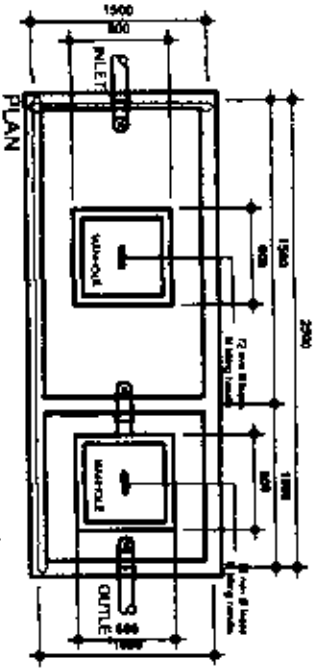

PROPOSED TRIPLE-POCKET BUILDING
CATCH BASIN DETAILS
TYPICAL

LEGEND :

FD	FLOOR DRAIN	60.3 mm (2 3/8") PVC PERVERTER
SD	SHOWERS DRAIN	60.3 mm (2 3/8") PVC PIPE
ST	SEPTIC TANK	75.2 mm (3") PVC PIPE
CB	CATCH BASIN	60.3 mm (2 3/8") PVC PIPE
FCO	FLOOR CLEAN OUT	152.4 mm (6") 20 PVC PIPE
WCO	WALL CLEAN OUT	152.4 mm (6") 20 PVC PIPE
CO	CLEAN OUT	25 mm (1") 20 PVC PIPE
VTR	VENT THRU ROOF	HOT WATER LINE
KB	KITCHEN SINK	HWT
WC	WATER CLOSET	CWL
LAV	LAVATORY	DWV
F	FAUCET	CV
HB	HOSE BIB	HW
SH	SHOWER HEAD	QV
BT	BATH TUB	R
RM	RADIATOR	UM
		UNVAL

PLUMBING NOTES:

1. ALL MATERIALS, PARTS & EQUIPMENT TO BE USED IN THE PLUMBING INSTALLATION SHALL BE AS SHOWN ON THE APPROVED TYPE & SIZE AS TO THE APPROVED MAKE.
2. ALL INSTALLATION SHALL BE IN CONFORMANCE WITH THE PLUMBING CODE OF THE STATE OF CALIFORNIA & THE CITY OF LOS ANGELES.
3. DRAINAGE PIPING SHALL BE PROVIDED WITH APPROVED CLEANOUT FITTINGS FOR EACH CONNECTION, CORRECTLY LOCATED ACCORDING TO THE CODE & TYPE OF SERVICE PROVIDED TO BE COMPLETED.
4. CHANGE IN DIRECTION OF DRAINAGE PIPING SHALL BE MADE WITH APPROVED USE OF APPROVED FITTINGS & SHALL BE OF THE SAME OR HIGHER RATED BY A 1/2" BEND. USE OF 90° OR OTHER APPROVED FITTINGS OR EXHAUST AIR SYSTEMS, SHALL BE PROHIBITED.
5. PROVIDE CLEANOUT FROM EACH CHANGE IN DIRECTION OF THE TOTAL APPROPRIATE CHANGE EXCEPT 180°.
6. EXISTING CLEANOUT SHALL BE INSTALLED SO THAT IT OPERATES IN DIRECT OPPOSITE TO THE FLOOR OR CEILING OR WALL OR AT RIGHT ANGLES THERE TO. APPROVED CLEANOUTS SHALL BE INSTALLED AT INTERVALS NOT TO EXCEED 10 FT (3.05 M) IN STRAIGHT RUNS.
7. HORIZONTAL, UNINSULATED PIPING SHALL BE IN PRACTICAL ALIGNMENT & A SLOPE OF 1/8" OR NOT LESS THAN 1/8" OR AN INCH PER FOOT MINIMUM ON IN TOWARD THE POINT OF DISCHARGE.
8. LINES TO BE PROVIDED BY STRUCTURAL CONTRACTOR, EACH LINE SHALL BE VERTICALLY TO A POINT NOT LESS THAN 4" (102 mm) ABOVE THE FLOOR FINISH, TOP OF THE FLOOR FINISH OR TOP OF CEILING FINISH, WHICHEVER IS HIGHER.
9. EACH TRAP PIPE OR SINKER SHALL EXTEND THROUGH THE CEILING & SHALL TERMINATE VERTICALLY THROUGH THE CEILING AT A POINT NOT LESS THAN 1" (25.4 mm) ABOVE THE ROOF & ONE FOOT (305 mm) FROM ANY OTHER VERTICAL SURFACE.
10. PIPING SHALL BE Laid ON A FIRM, SLEW THROUGHOUT THE ENTIRE LENGTH, & AT EACH ENDING TO BE Laid ON SLEW OR FILLER GROUND, IT SHALL BE Laid ON A SLEW OR APPROVED MATERIALS & SHALL BE ABSOLUTELY UNMOUNTED.

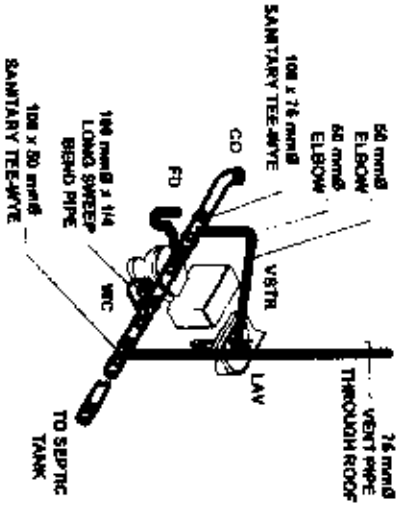

PROPOSED TRIPLE-POCKET BUILDING
TYPICAL TRAY-OUT
TYPICAL

REG. NO.: VALID UNTIL: FTR NO.: DATE: THE NO.: PLACE:	OWNER: NESCO II AREA-1	PROJECT: PROPOSED TRIPLE-POCKET BUILDING LAJAVISA, NEVADA/CIA	SHEET COMMENT: SEPTIC TANK DETAILS CATCH BASIN DETAILS TRAY-LAY-OUT	DWG./SHEET NO.: P-03
--	---------------------------	---	--	--------------------------------